

BELLOW SEAL GLOBE VALVES



BELLOW SEAL GLOBE VALVE

Straight-type bellows seal valves offer reliable zero-leakage sealing, ideal for high-temperature or hazardous media. The Compact, inline design is perfect for vertical or space-limited installations.

Equipped with a welded metal bellows and dual sealing structure, these valves ensure long service life, safety, and precision under demanding conditions.

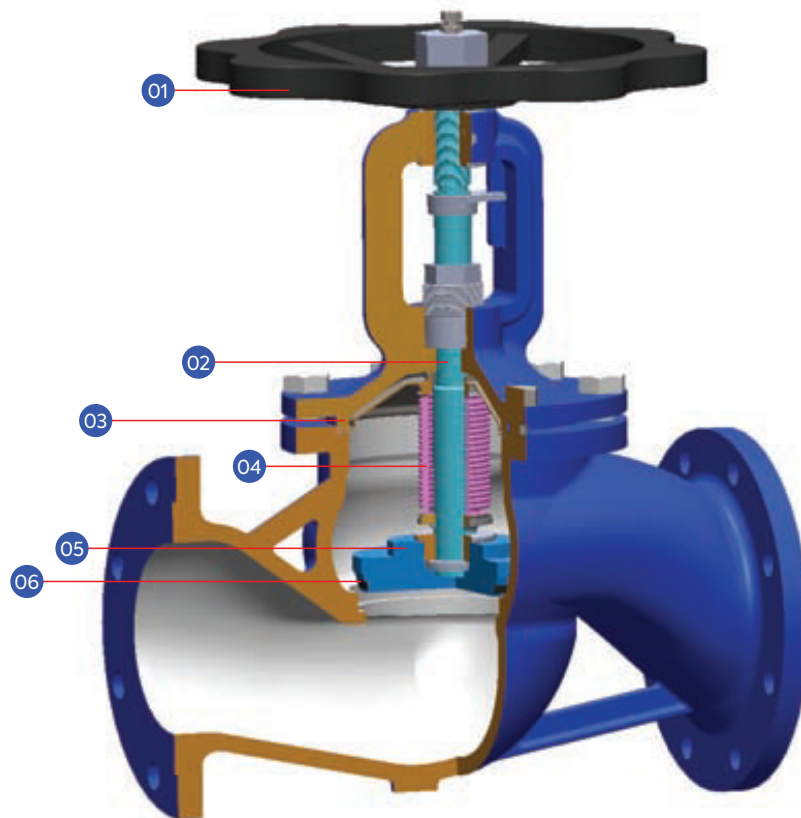

- 1. Oversized Handwheel**
Oversized handwheel for easy handling and position indicator allows user to know (OPEN / CLOSE) status of the valve.
- 2. Backseat On Stem**
Metal back seat has been provided to arrest leakage to the atmosphere in case of bellow failure.
- 3. Tongue and Groove Body And Bonnet**
Tongue and Groove Body and Bonnet designed to avoid any leak between joints.
- 4. High Quality Multiply Bellow**
Completely welded multiple layer stainless steel bellows are secured against torque and designed to last as per MSS SP-117 cycle life.
- 5. Standard 360° Free Rotation and Conical Plug**
Standard 360° free rotation and conical plug provides a tighter closure while maintaining seat clean from shards. Both seat and plug are made out of hardened chromium steel 1.4021 or with stellite.
- 6. Plug and Seat Hard Faced**
TA-LUFT certified full size safety gland packing made of pure graphite together with our bellows, guaranteeing 100% zero leak to the atmosphere. Can also be supplied in PTFE on request for other chemical applications.

Y TYPE DESIGN

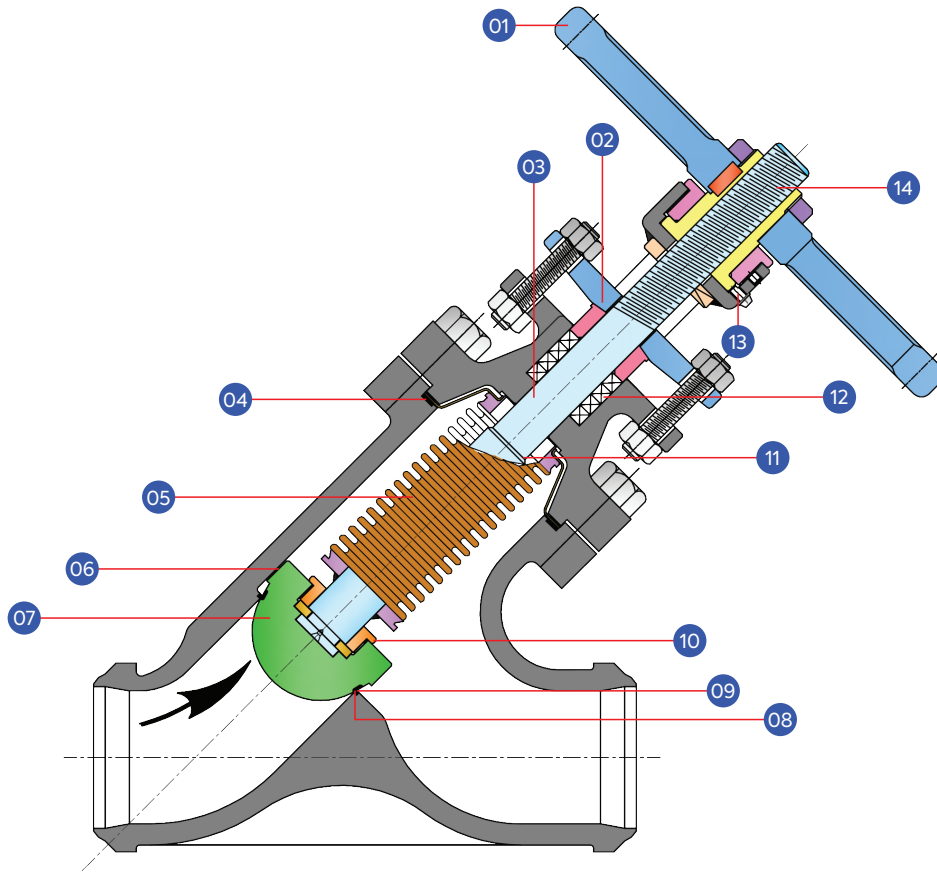

1. Non Rising Hand Wheel

- Ideal in restricted spaces

2. Ease of operation for Secondary Packing

- Ease for replacing packing
- Improves proper sealing

3. Non Rotating Stem

- High reliability
- Twist of bellow is avoided
- Longer packing life

4. Body-bonnet Joints

- Tongue and groove arrangement
- No gasket slip possible, long service life

5. Multiply Bellows

- High service life

6. Guided Plug

- Body bore guided plug design

7. Throttling type plug design

8. Hardfacing or Stellite

- Increased service life

9. Integral Body Seat

- Avoid leak through seating

10. Plug and Stem connected by stem nut

- Provides 360° rotation of plug

11. Back Seat Arrangement on Stem

- Additional tertiary safety
- Anti-blow out under line pressure

12. Downstream Safety Gland Packing with Graphite

- Additional reliability against bellow failure

13. Provision for Lubrication on Yoke Sleeve

- Ensures smooth operation

14. ACME Stem Thread

- Longer service life

WHY OUR VALVES ARE BETTER

Straight type bellow sealed globe valves for demanding applications can be supplied in carbon steel 1.0619 / WCB and stainless steel 1.4408 / CF8M, both with flanged or buttweld ends.

Application (Carbon Steel)

The body and bonnet of the ValveWerkz bellow seal globe valve are made from A105 material. The condensate discharge temperature is adjustable and is factory-set between 120°C and 130°C.

Medium (Carbon Steel)

Medium and high pressure steam, superheated steam, gases, thermal oil, overheated water and gases, etc.

Application (Stainless Steel)

Recycling plants, chemical industry, process water installations, process with aggressive media.

Medium (Stainless Steel)

Process water, aggressive media, corrosive and toxic fluids, ethylene dioxide, H₂SO₄, etc.

Features	ValveWerkz	Others
Stem with back seat	Yes	No
360° free rotation disc	Yes	On Request
Stroke limiter	Yes	On Request
Wide thread stem that prevents the valve from blocking	Yes	No
Tongued body and bonnet	Yes	No

Multi Layer Bellow (ValveWerkz)

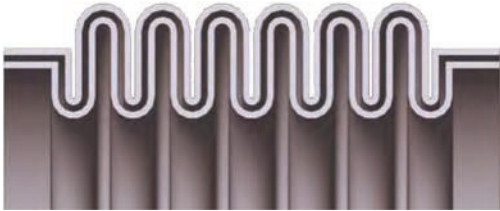

- Multiple bellows depending on the pressure of the valve.
- Bellows designed to better MSS SP-117.
- Bellows are welded to the stem and not to the disc, preventing the transmission of vibrations to the bellows, and therefore extending the life of the bellows.

Others

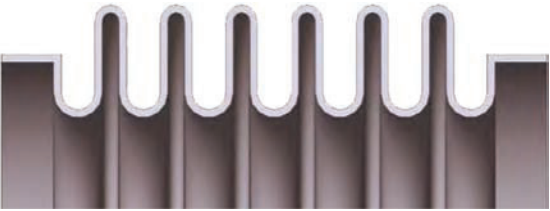

- Just one bellow layer, which means a lower resistance to breakage.
- Bellows designed to support less than 10,000 operation cycles.
- Bellows are welded to the disc, which transmits the vibrations to the bellows, decreasing their lives.

BELLOWS AS A LEAKAGE BARRIER

Our stainless steel 316Ti German manufactured bellows is welded to the stem, becoming a definitive metallic barrier between the process medium and the atmosphere, and hence guarantying zero leakage performance. Still, for higher security, safety TA-LUFT approved packing is applied in design. Furthermore, our multiple layer bellows are designed to last at least 30,000 cycles according to MSS SP-117 manufacturing standard.

Multi Layer Bellows

- Double, triple and quadruple layer bellows depending on the size of the valve.
- Bellows designed to support 30,000 operation cycles.
- Bellows are welded to the stem and not to the disc, preventing the transmission of vibrations to the bellows, and therefore extending the life of the bellows.



Kvs Value Standard Plug

DN	15	20	25	32	40	50	65	80	100	125	150	200	250	300
KVS	4.8	7.3	11.7	17.8	27.3	43	75.1	111	176	264	369	701	1056	1691

Throttling Plug Kvs Value

DN	15	20	25	32	40	50	65	80	100	125	150	200	250	300
KVS	4.36	6.76	9.21	16.3	25.1	36.8	61.7	91.6	137	184	287	471	898	1410

Optional Plug Types

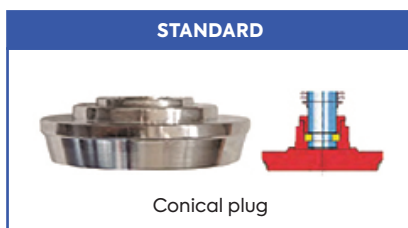

Permissible differential pressure acc. EN13709

PN	DN													
	15	20	25	32	40	50	65	80	100	125	150	200	250	300
PN16							16					14	9	6
PN25							25				21	14	9	6
PN40							40			33	21	14	9	6



Applications

- Hot oil system, steam system, hot and cold water system etc.

GL25 Series Straight Type

Body Material

Cast Iron, GG25	Forged Steel / A105
Ductile Iron, GGG40	St. St. 304
Carbon Steel 1.0619	St.St 316 / 1.4571

Plug material & Design

St. Steel 1.4021 + Hard Faced 13% Cr
Parabolic (For regulating)
Conical (For On Off)
Balancing (For 5" and above, high pressure)

Bellow Material

321 Ti	St.St 304
St.St 316 / 1.4571	Hastelloy C
BSPT - Tapered	NPT
Socket Weld	Flanged End
Butt Weld	

DN15 (½") to DN150 (6")

For Standard Plug: KVS = 4.8 - 1691

For Throttling Plug: KVS = 4.36 - 1410

ANSI 150	ANSI 600	PN16	PN40
ANSI 300	ANSI 900	PN25	

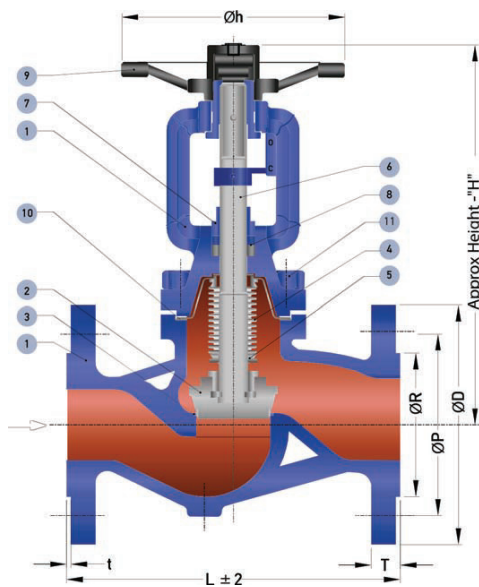

Part Name	PN16	PN25
1. Body & Bonnet	EN-JL 1040 Cast Iron	EN-GJS-400-18-LT Ductile Iron
2. Plug	St. Steel 1.4021 + Hard Faced 13% Cr	
3. Seat	ASTM - A105 + Hard Faced 13% Cr	
4. Bellow	St. Steel 1.4541 / AISI-321	
5. Bellow Collar	St. Steel 1.4541	
6. Stem	St. Steel 1.4006	
7. Gland	St. Steel 1.4021	
8. Packing	Pure Graphite	
9. Hand Wheel	EN-GJS-400-18-LT Nodular	
10. Bonnet Gasket	Graphite + Stainless Steel	
11. Bolt & Nuts	Carbon Steel Gr. 10.9	

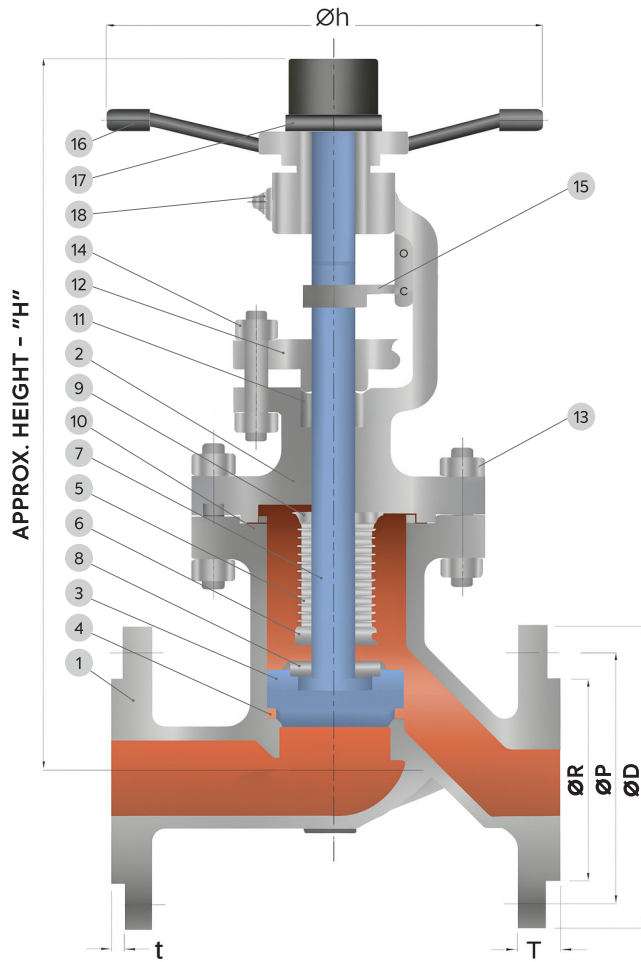

Part Materials

Nominal Pressure	PN40	
1. Body	1.0619/ ASTM - A 216 Gr. WCB	1.4408/ ASTM - A351 Gr. CF8M (1.4408)
2. Bonnet	1.0619/ ASTM - A 216 Gr. WCB	1.4408/ ASTM - A351 Gr. CF8M (1.4408)
3. Plug	ASTM - A217 Gr. CA15 + 13% Cr. Overlay	1.4408/ ASTM - A351 Gr. CF8M (1.4408) + Stellite Gr. 6
4. Integral Seat	1.0619/ ASTM - A216 Gr. WCB + 13% Cr. Overlay	1.4408/ ASTM - A351 Gr. CF8M (1.4408) + Stellite Gr. 6
5. Bellow	1.4541 / AISI-321	1.4571/ AISI - 316Ti
6. Bellow Collar	1.4401 / ASTM - A 276 TYPE 316	1.4401 / ASTM - A 276 TYPE 316
7. Stem	1.4006 / ASTM - A 276 TYPE 410	1.4401 / ASTM - A 276 TYPE 316
8. Collar Ring	1.4006 / ASTM - A 276 TYPE 410	1.4401 / ASTM - A 276 TYPE 316
9. Top Collar	1.4401 / ASTM - A 276 TYPE 316	1.4401 / ASTM - A 276 TYPE 316
10. Gasket	SPW- SS304 + Graphite	
11. Packing	Graphite	
12. Gland bush/Flange	1.0619/ ASTM - A216 Gr. WCB	1.4408/ ASTM - A351 Gr. CF8M
13. Fastener	ASTM - A 193 Gr. B7/ A 194 Gr. 2H	ASTM - A 193 Gr. B8M/ A 194 Gr. 8M
14. Gland Stud & Nut	ASTM - A 193 Gr. B7/ A 194 Gr. 2H	ASTM - A 193 Gr. B8M/ A 194 Gr. 8M
15. Guide Plate/Indicator	Carbon Steel	1.4408/ ASTM - A351 Gr. CF8M
16. Hand Wheel	Mild Steel/ Nodular Cast Iron	
17. Hand Wheel Nut/Cap	Carbon Steel	1.4401 / AISI -316
18. Grease Nipple	Carbon Steel	1.4401 / AISI -316

Working Conditions

Temperature (°C)	Pressure (Bar)				
	Cast Iron EN-JL 1040	Ductile Iron EN-GJS-400-18-LT	Carbon steel WCB (1.0619)	Stainless Steel CF8M (1.4408)	
	PN16		PN25	PN40	
-60/-10					40.0
-10/120 -10/100*	16.0	16.0	25.0	40.0	40.0*
150	14.4	15.5	24.3	35.2	36.3
200	12.8	14.7	23.0	33.3	33.7
250	11.2	13.9	21.8	30.4	31.8
300	9.6	12.8	20.0	27.6	29.7
350		11.2	17.5	25.7	28.5
400				23.8	27.4

Dimensions(mm)

DN	PN	ØD (Outer Flange Diameter)	ØP (Bolt Circle)	ØR	T	t	No. of Hole /Ø	L (Face to face)	Øh	Stroke	H (Closed)	Weight (kg)
15	16	95	65	46	16	2	4/Ø14	130	172	4.0	215	4.8
	25	95	65	46	16	2	4/Ø14	130	172	4.0	215	5.0
	40	95	65	45	16	2	4/Ø14	130	172	4.0	260	8.5
20	16	105	75	56	16	2	4/Ø14	150	172	5.0	220	5.2
	25	105	75	56	18	2	4/Ø14	150	172	5.0	220	5.5
	40	105	75	58	18	2	4/Ø14	150	172	5.0	275	9.5
25	16	115	85	65	17	3	4/Ø14	160	172	6.5	230	6.0
	25	115	85	65	19	3	4/Ø14	160	172	6.5	230	6.4
	40	115	85	68	18	2	4/Ø14	160	172	7.0	290	11.5
32	16	140	100	76	18	3	4/Ø19	180	172	8.0	235	7.8
	25	140	100	76	19	3	4/Ø19	180	172	8.0	235	8.3
	40	140	100	78	18	2	4/Ø18	180	200	8.0	297	17.0
40	16	150	110	84	19	3	4/Ø19	200	200	10.0	255	11.2
	25	150	110	84	19	3	4/Ø19	200	200	10.0	265	11.5
	40	150	110	88	18	3	4/Ø18	200	200	10.0	331	19.0
50	16	165	125	99	20	3	4/Ø19	230	200	13.0	265	13.6
	25	165	125	99	20	3	4/Ø19	230	200	13.0	275	14.2
	40	165	125	102	20	3	4/Ø18	230	200	13.0	350	21.5
65	16	185	145	118	20	3	4/Ø19	290	250	16.5	325	22.9
	25	185	145	118	22	3	8/Ø18	290	250	16.5	325	24.8
	40	185	145	122	22	3	8/Ø18	290	250	16.0	435	33.5
80	16	165	160	132	22	3	8/Ø19	310	250	20.0	335	27.4
	25	165	160	132	24	3	8/Ø19	310	250	20.0	355	27.9
	40	165	160	138	24	3	8/Ø18	310	300	19.0	455	45.0
100	16	220	180	156	24	3	8/Ø19	350	300	25.0	385	40.3
	25	235	190	156	24	3	8/Ø28	350	300	25.0	410	42.2
	40	235	190	162	24	3	8/Ø22	350	300	25.0	540	61.5
125	16	250	210	184	26	3	8/Ø19	400	350	32.0	425	67.2
	25	270	220	184	26	3	8/Ø28	400	350	32.0	450	67.0
	40	270	220	188	26	3	8/Ø26	400	350	32.0	640	102.0
150	16	285	240	211	26	3	8/Ø23	480	400	51.0	485	89.2
	25	300	250	211	28	3	8/Ø28	480	400	38.0	525	91.0
	40	300	250	218	28	3	8/Ø26	480	400	38.0	695	122.0
200	16	340	295	266	30	3	12/Ø23	600	450	64.0	615	143.5
	25	360	310	274	34	3	12/Ø28	600	450	51.0	640	147.0
	40	375	320	285	34	3	12/Ø30	600	450	50.0	825	22.0
250	16	400	355	319	32	3	12/Ø28	730	500	62.5	780	241.0
	25	425	370	330	38	3	12/Ø31	730	500	62.5	820	246.0
	40	450	385	345	38	3	12/Ø33	730	600	70.0	1,010	362.0
300	40	515	450	410	42	4	12/Ø33	850	600	80.0	1,210	533.0

REQUEST FOR QUOTE



STEP 1

Find the model series



STEP 2

Define the specification/valve code



STEP 3

Fill up ordering sheet (back of the brochure) or Scan the QR code below



STEP 4

Submit your order via our website or contact your local partner



STEP 5

Prepare for confirmation and delivery

*For further assistance with placing your order, please contact your local partner. A sales engineer will be assigned to assist you.

Valve Coding Sheet GL25 Series (S-Type)

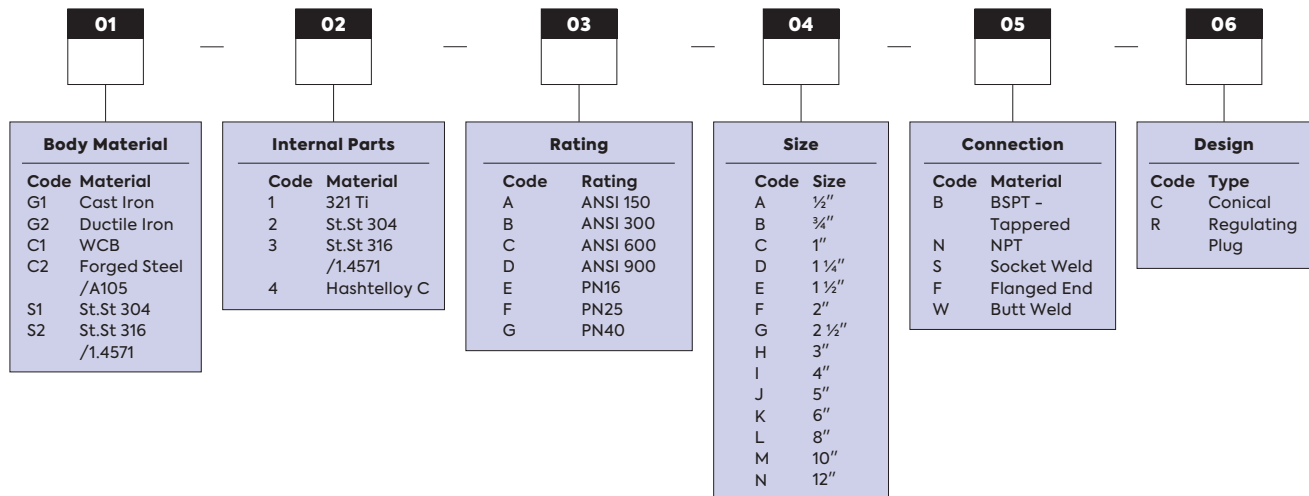

Your Valve Ordering Code:

GL25 —

Example:

GL25 Series (S-Type) – C21GDFR.
Forged Steel / A105. 321 Ti Internal Parts. Pressure Rating of PN40, ½ inch size.
Connection Type of Flanged End. Design Regulating Plug.

*For special material or customisation, please refer to our sales engineer.



SCAN FOR ONLINE ORDERING FORM

Tel: +65 6909 1221
Email: enquiry@valvewerkz.com
Website: www.valvewerkz.com



Applications

Steam, hot and cold water, oil products, acetic acid, fatty acids, cryogenic liquids, ammonia, natural gas, etc.

GL26 Series Y Type

Body Material

Cast Iron GG25	Forged Steel / A105
Ductile Iron GGG40	St. St. 304
Carbon Steel 1.0619	St.St 316 / 1.4571

Plug Material & Design

St. Steel 1.4021 + Hard Faced 13% Cr
Parabolic (For regulating)
Conical (For On Off)
Balancing (For 5" and above, high pressure)

Bellow material

321 Ti	St.St 304
St.St 316 / 1.4571	Hastelloy C

BSPT - Tapped	NPT
Socket Weld	Flanged End
Butt Weld	

DN15 (1/2") to DN150 (6")

For Standard Plug:

KVS = 4.8 - 1691

For Throttling Plug:

KVS = 4.36 - 1410

ANSI 150	PN16
ANSI 300	PN25
ANSI 600	PN40
ANSI 900	

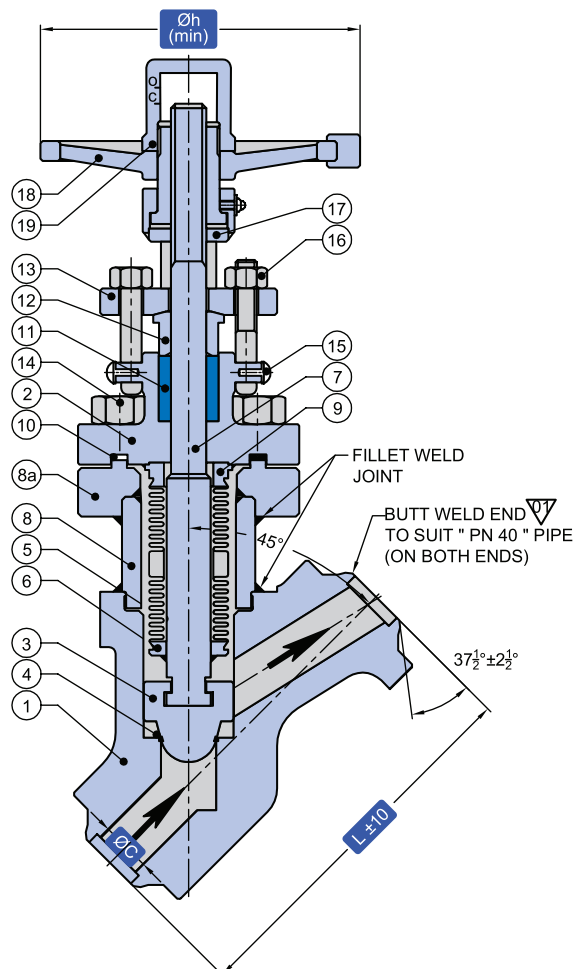

Part Materials

Nominal Pressure	PN40		300#
1. Body	ASTM - A 105	ASTM - A 182 Gr.F316L	SS317LMN
2. Bonnet	ASTM - A 105	ASTM - A 182 Gr.F316L	1.4439
3. Parabolic Plug	ASTM - A 276 TYPE 410 / A 217 Gr.CA15 + Hard Faced	ASTM - A 276 TYPE 316L + Stellite Gr.21	AISI - 317L + Stellite Gr.21
4. Integral Seat	ASTM - A 105 + Hard Faced	ASTM - A 182 Gr.F316L + Stellite Gr.21	1.4439 + Stellite Gr.21
5. Bellow	AISI - 316Ti / AISI - 321		Hastelloy - C276
6. Bellow Collar	ASTM - A 276 TYPE 316 / 316L		Hastelloy - C276
7. Stem	ASTM - A 276 TYPE 410	ASTM - A 276 TYPE 316L	AISI - 317L
8. Cylinder / Stem Nut (For Ss317l)	ASTM - A 106 Gr.B	ASTM - A 312 TYPE 316L	AISI - 317L
8a. Cylinder Flange	ASTM - A 105	AISI - 316L	
9. Top Collar	ASTM - A 276 TYPE 316 / 316L		Hastelloy - C276
10. Gasket	SPW- SS304 + Graphite		
11. Packing	Graphite		
12. Gland Bush	ASTM - A 276 TYPE 410 / A 217 Gr.CA15	ASTM - A 276 TYPE 316L / A 351 Gr.CF3M	AISI - 317L
13. Gland Flange	ASTM - A 105 / Carbon Steel	ASTM - A 240 TYPE 304 / A 351 Gr.CF8	
14. Hex Bolt / Fastener	ASTM - A 193 Gr.B7		ASTM - A 193 Gr.B8
15. Rivet / Washer / Gland Stud / Nut	Carbon Steel	AISI - 304	ASTM - A 240 TYPE 304 / A 351 Gr.CF8
16. Eye Bolt / Nut	ASTM - A 193 Gr.B7 / A 194 Gr.2H	ASTM - A 193 Gr.B8 / A 194 Gr.8	
17. Guide Plate	ASTM - A 216 Gr.WCB / Carbon Steel	ASTM - A 276 TYPE 304 / A 351 Gr.CF8	ASTM - A 276 TYPE 304 / A 351 Gr.CF8
18. Hand Wheel	SG IRON / ASTM - A 216 Gr.WCB	SG IRON / ASTM - A 216 Gr.WCB / IS 2062 Gr. E 250 A	SG IRON / ASTM - A 216 Gr.WCB
19. Hand Wheel Nut / Key	Carbon Steel	AISI - 304	

Working Conditions

Temperature (°C)	Pressure (Bar)		
	ASTM - A 105	ASTM - A 182 Gr.F316L	SS317LMN
	PN40		ANSI300
-29 to 38	51.1	41.4	41.4
50	50.1	40.4	40.4
100	46.6	34.8	34.8
150	45.1	31.4	31.4
200	43.8	29.2	29.2
250	41.9	27.5	27.5
300	39.8	26.1	26.1
325	38.7	25.5	25.5
350	37.6	25.1	25.1
375	36.4	24.8	24.8
400	34.7	24.3	24.3
425	28.8	23.9	23.9

Dimensions(mm)

DN	PN/ANSI	Body Material	L	H	Øh	Bore Dimension ØC (min)
15	40	ASTM - A 105	150	235	100	9
	300#	ASTM - A 182	130	250	100	12
		Gr.F316L SS317LMN	152	240	150	
20	40	ASTM - A 105	150	240	100	12
	300#	ASTM - A 182	150	266	100	17
		Gr.F316L SS317LMN	178	155	150	
25	40	ASTM - A 105	150	245	100	17
	300#	ASTM - A 182	160	265	150	
		Gr.F316L SS317LMN	203	265	150	
40	40	ASTM - A 105	229	305	200	
	300#	ASTM - A 182	200	305	200	
		Gr.F316L SS317LMN	229	305	200	
50	40	ASTM - A 105	267	335	200	
	300#	ASTM - A 182	230	335	200	
		Gr.F316L SS317LMN	267	335	200	
65	40	ASTM - A 105	292	450	250	
	300#	ASTM - A 182	290	450	250	
		Gr.F316L SS317LMN	292	450	250	
80	40	ASTM - A 105	318	505	300	
	300#	ASTM - A 182	310	505	300	
		Gr.F316L SS317LMN	318	505	300	
100	40	ASTM - A 105	356	605	300	
	300#	ASTM - A 182	350	605	300	
		Gr.F316L SS317LMN	356	605	300	
125	40	ASTM - A 105	400	660	350	
	300#	ASTM - A 182	400	670	350	
		Gr.F316L SS317LMN	400	670	350	
150	40	ASTM - A 105	444	760	350	
	300#	ASTM - A 182	480	750	350	
		Gr.F316L SS317LMN	444	760	350	
200	40	ASTM - A 105	559	900	450	
	300#	ASTM - A 182	600	900	400	
		Gr.F316L SS317LMN	559	900	450	

REQUEST FOR QUOTE



STEP 1

Find the model series



STEP 2

Define the specification/valve code



STEP 3

Fill up ordering sheet (back of the brochure) or Scan the QR code below



STEP 4

Submit your order via our website or contact your local partner



STEP 5

Prepare for confirmation and delivery

*For further assistance with placing your order, please contact your local partner. A sales engineer will be assigned to assist you.

Valve Coding Sheet GL26 Series (Y-Type)

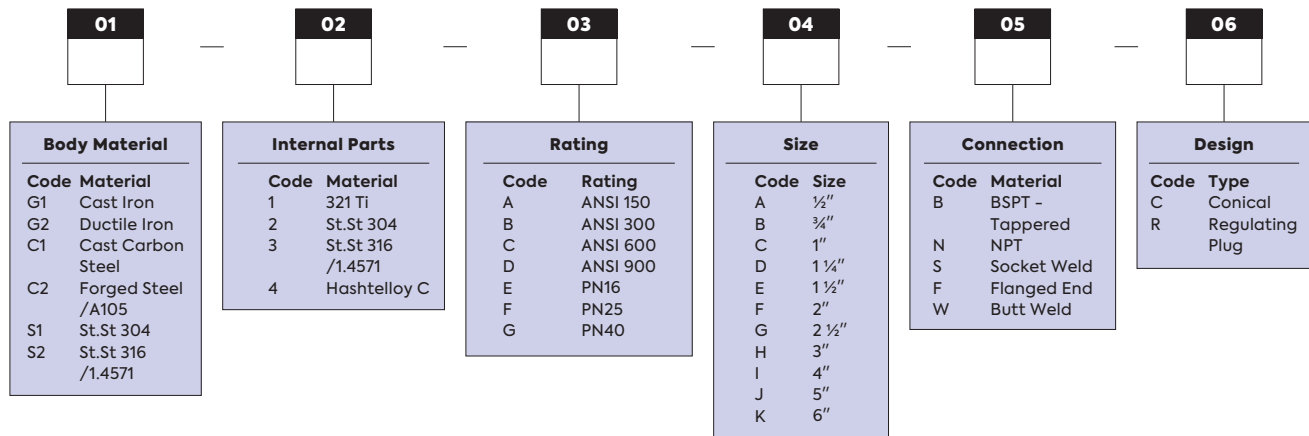

Your Valve Ordering Code:

GL26 —

Example:

GL26 Series (Y-Type) - C21GDFR.
Forged Steel / A105. 321 Ti Internal Parts. Pressure Rating of PN40, 1 ¼ inch size. Connection Type of Flanged End. Design Regulating Plug.

*For special material or customisation, please refer to our sales engineer.



SCAN FOR ONLINE ORDERING FORM

Tel: +65 6909 1221
Email: enquiry@valvewerkz.com
Website: www.valvewerkz.com