

STEAM TRAPS



BALL FLOAT STEAM TRAP

Ball float steam traps are known for their high discharge capacity, long service life, excellent energy efficiency, resistance to water hammer, and sleek design. They are commonly used in process heat tracing, jacketed heating kettles, reboilers, and various other equipment.

ValveWerkz steam traps stand out for their unique and well-engineered internal structure, delivering high precision and reliable performance.

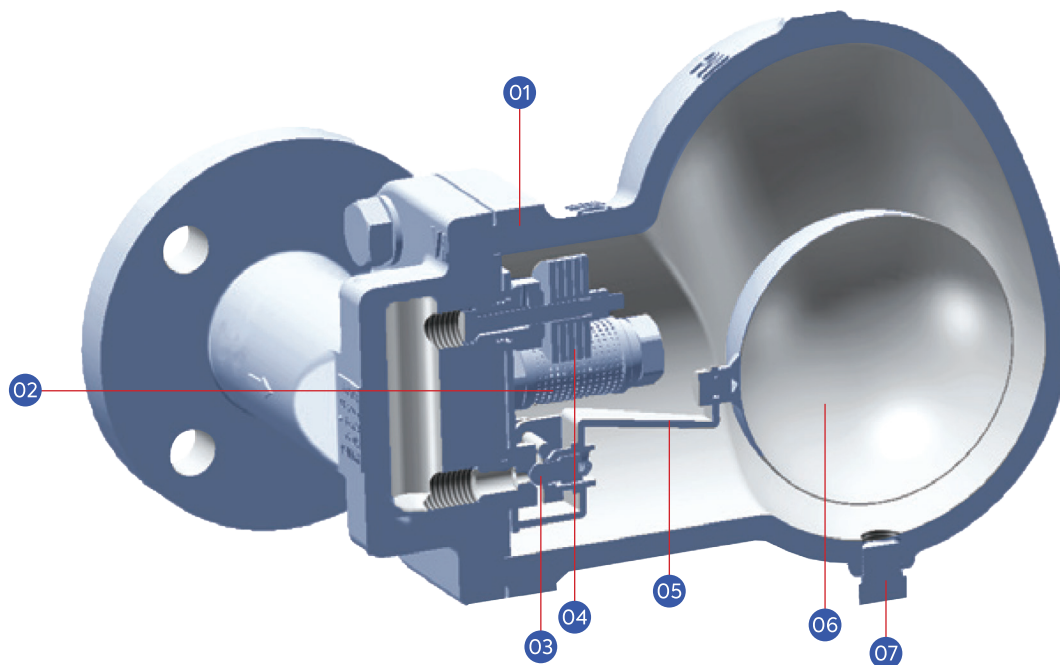

1. High-Strength Corrosion Resistance

Constructed with WCB material, the design fully accounts for corrosion allowance, shell wall thickness, and pressure and temperature ratings.

2. Integrated Filtering Device

Effectively blocks pipeline impurities from entering the valve, ensuring reliable trap operation.

3. Precision Closing System

Micron-level valve seat and core deliver high sealing reliability, preventing steam leakage.

4. Optimised Exhaust Valve

The air exhaust valve prevents blockage from non-condensable gases (e.g. air) during startup or normal operation.

5. Engineered Float Assembly

Precisely calculated floating ball design enables consistent closure under water seal conditions without steam loss.

6. Stainless Steel Float

The laser-welded stainless steel float offers exceptional durability and a long service life.

7. Dedicated Sewage Outlet

Reserved outlet design allows for effective discharge of accumulated residue.

Structural Features

ValveWerkz incorporates a flexible closing system into its ball float steam trap, addressing common issues such as short service life and poor sealing. The design thoughtfully considers key factors including:

- Shell strength
- Pressure and temperature ratings
- Casting processability
- Fluid flow paths
- Water and steam mixing impact
- Auxiliary water seal closure
- Gasket performance in low-temperature environments

The ball float steam trap operates based on the density difference between steam and

condensate. When the valve body fills with condensate and non-condensable gases, the air exhaust valve opens to release the gas. As condensate is drained, the float ball rises, lifting the valve core to open the trap. Once drainage is complete, the float lowers and closes the valve.

The primary advantages of the ball float steam trap include:

- High back pressure tolerance (capable of operating with pressure differences as low as 0.01 bar)
- Long service life
- Reliable performance
- Easy maintenance
- Zero steam leakage during normal operation

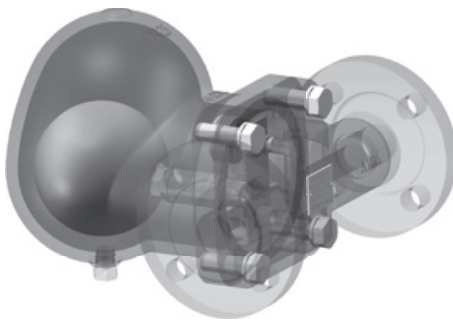

Material and Performance Specifications

The ball float steam trap is manufactured from ASTM A216 WCB cast steel, with parts of the valve cover made from ASTM A105. The internals are constructed from stainless steel and include a built-in filter.

Nominal pressure: PN25

Maximum allowable temperature: 425°C

Maximum working pressure: 16 Bar

Maximum working temperature: 400°C

Connection type: Threaded RC or flange (GB/T 9115.1-2000; HG/T20515-2009; HG/T20592-2009, etc.)

Selection and Installation

The ball float steam trap provides continuous drainage. It operates with a subcooling level of approximately 5°C and supports a back pressure ratio above 95% (back-end pipeline pressure to steam pressure). This makes it ideal for pipelines and Compact equipment where condensate removal and back pressure recovery are required.

When selecting a model, it's recommended to apply:

- A safety factor of 2 - 3 times for standard applications
- A safety factor of 5 - 8 times for air separation units and drying cylinders

The volume of condensate and the pressure differential in the steam system are key indicators when choosing the correct trap type. For the same model, displacement increases as pressure difference rises, it is important to refer to the displacement curve for accurate selection.

Special Reminder

Do not confuse high displacement with a trap intended for large-diameter piping. Displacement does not equate to physical size.

Valve Body Pressure - Rating Temperature (25 Bar; WCB)

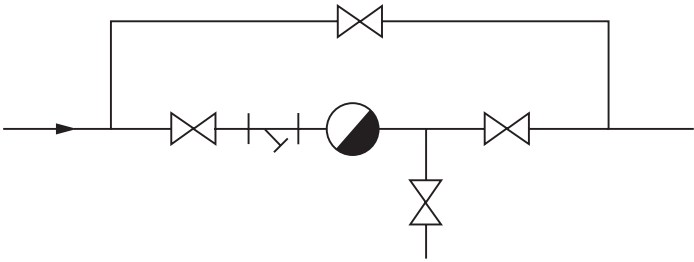
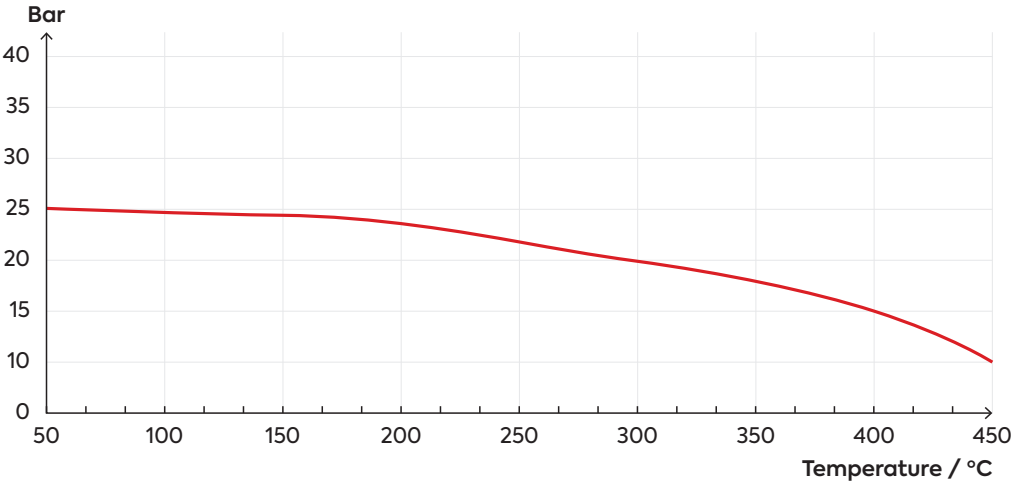

The bimetal steam trap can be installed at any point along the pipeline or within equipment. The diagram above illustrates the standard configuration for proper installation.

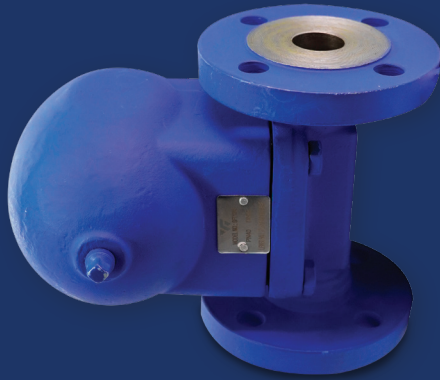

ST60 Series

Ball Float Steam Trap

Carbon Steel
SS304

SS304

Threaded End
Socket Weld End
Flanged End

DN15 (1/2") to DN80 (3")

Max Discharge = 150 T/hr

PN25 - PN100

Max W.P = 16 - 100 Bar

ST60.1 | Max Capacity = 900 kg/h

Displacement Curve

Technical Parameters	
Nominal pressure	PN40
Max. allowable pressure (Shell)	39.2 Bar / 200°C
Max. allowable temperature (Shell)	450°C / 16.6 Bar
Factory steam action test	>3 times / 16 Bar
Max. operating pressure	32 Bar
Max. operating temperature	350°C
Factory cold test pressure	60 Bar
Air test	20 Bar

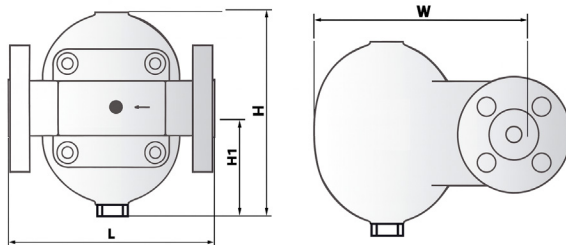
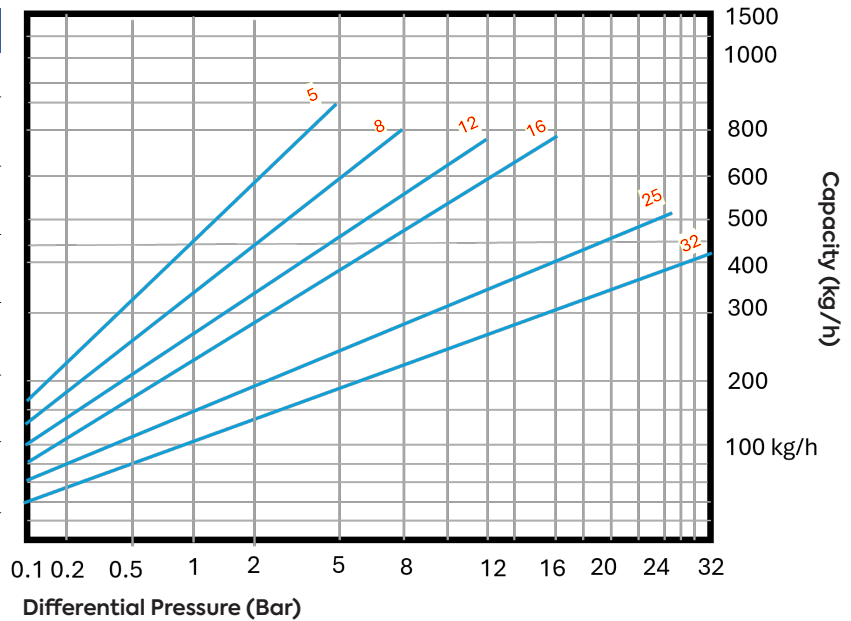

Part Name	Material
Bonnet	A105 / F304 / F316
Body	WCB / CF8 / CF8M
Seat	420
Disc	440C
Other Internal Parts	304

Data Size Table

Connection	Size	L(mm)	H (mm)	H1 (mm)	W (mm)	Weight(kg)
Threaded	DN15 - 20	120	154	82	155	5.0
	DN25	145	154	82	155	5.7
Butt Weld / Socket Weld	DN15 - 20	120	154	82	155	5.0
	DN25	145	154	82	155	5.7
Flanged	DN15 - 20	150	154	82	155	7.0
	DN25	160	154	82	155	8.1

ST60.2 | Max Capacity = 1800 kg/h

Technical Parameters		Technical Parameters	
Nominal pressure	PN25	Max. operating pressure	16 Bar
Max. allowable pressure (Shell)	24.5 Bar / 200°C	Max. operating temperature	350°C
Max. allowable temperature (Shell)	450°C / 10.3 Bar	Factory cold test pressure	38 Bar
Factory steam action test	>3 times / 16 Bar	Air test	20 Bar

Displacement Curve

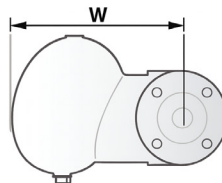
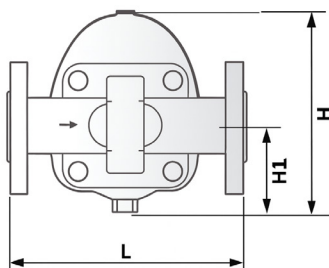
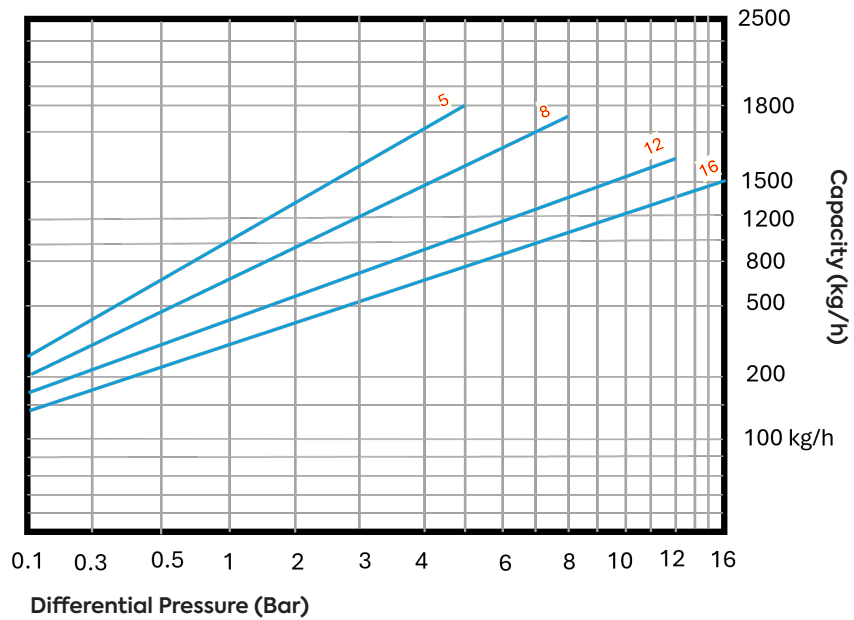

Part Name	Material
Bonnet	A105 / F304 / F316
Body	WCB / CF8 / CF8M
Seat	420
Disc	440C
Other Internal Parts	304

Data Size Table

Connection	Size	L(mm)	H(mm)	H1(mm)	W(mm)	Weight(kg)
Threaded	DN15- 25	150	180	75	183	8.5
Butt Weld / Socket Weld	DN15 - 25	150	180	75	183	8.5
Flanged	DN15 - 25	210	180	75	183	11

ST60.3 | Max Capacity = 2750 kg/h

Technical Parameters	
Nominal pressure	PN25
Max. allowable pressure (Shell)	24.5 Bar / 200°C
Max. allowable temperature (Shell)	450°C / 10.3 Bar
Factory steam action test	>3 times / 16 Bar

Technical Parameters	
Max. operating pressure	16 Bar
Max. operating temperature	350°C
Factory cold test pressure	38 Bar
Air test	20 Bar

Displacement Curve

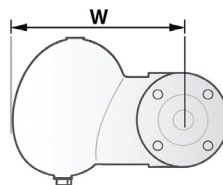
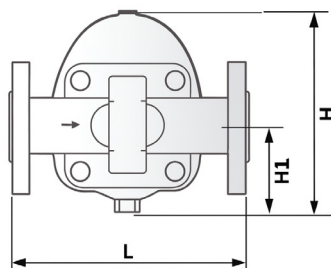
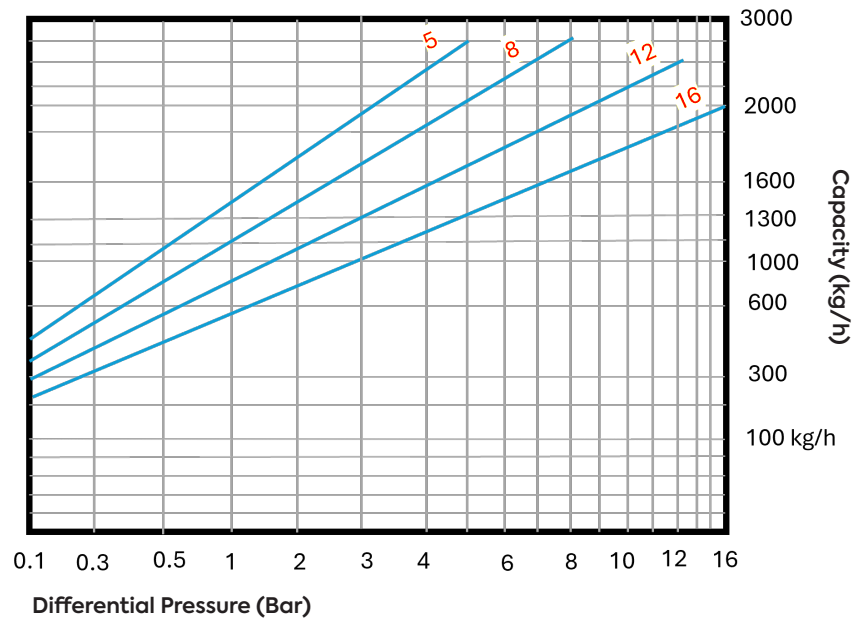

Part Name	Material
Bonnet	A105 / F304 / F316
Body	WCB / CF8 / CF8M
Seat	420
Disc	440C
Other Internal Parts	304

Data Size Table

Connection	Size	L (mm)	H (mm)	H1 (mm)	W (mm)	Weight (kg)
Threaded	DN25 - 32	170	210	90	235	12
Butt Weld / Socket Weld	DN25 - 32	170	210	90	235	12
Flanged	DN25 - 50	230	210	90	235	16.5

ST60.4 | Max Capacity = 4200 kg/h

Technical Parameters		Technical Parameters	
Nominal pressure	PN25	Max. operating pressure	16 Bar
Max. allowable pressure (Shell)	24.5 Bar / 200°C	Max. operating temperature	350°C
Max. allowable temperature (Shell)	450°C / 10.3 Bar	Factory cold test pressure	38 Bar
Factory steam action test	>3 times / 16 Bar	Air test	20 Bar

Displacement Curve

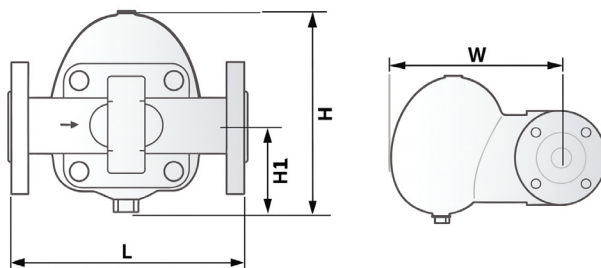
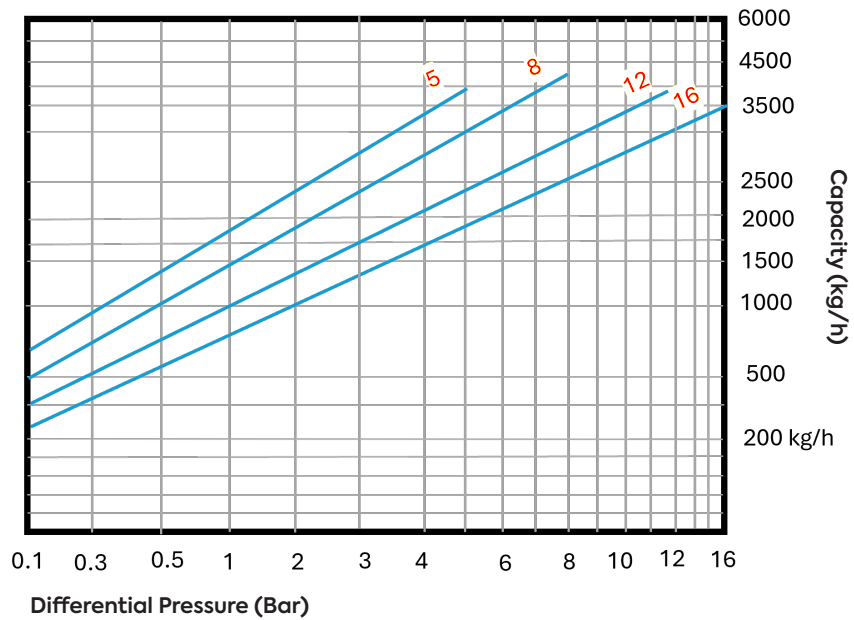

Part Name	Material
Bonnet	A105 / F304 / F316
Body	WCB / CF8 / CF8M
Seat	420
Disc	440C
Other Internal Parts	304

Data Size Table

Connection	Size	L(mm)	H(mm)	H1(mm)	W(mm)	Weight(kg)
Threaded	DN25 - 32	210	260	115	285	20
Butt Weld / Socket Weld	DN25 - 32	210	260	115	285	20
Flanged	DN25 - 50	270	260	115	285	26

ST60.5 | Max Capacity = 12500 kg/h

Technical Parameters	
Nominal pressure	PN40
Max. allowable pressure (Shell)	39.2 Bar / 200°C
Max. allowable temperature (Shell)	450°C / 16.6 Bar
Factory steam action test	>3 times / 16 Bar

Technical Parameters	
Max. operating pressure	32 Bar
Max. operating temperature	350°C
Factory cold test pressure	60 Bar
Air test	20 Bar

Displacement Curve

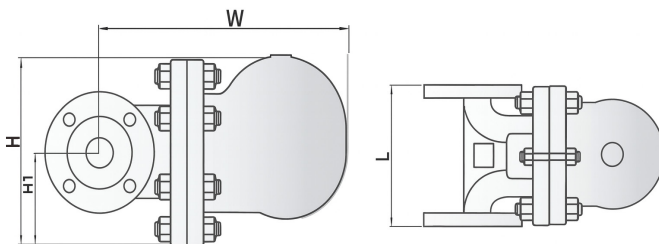
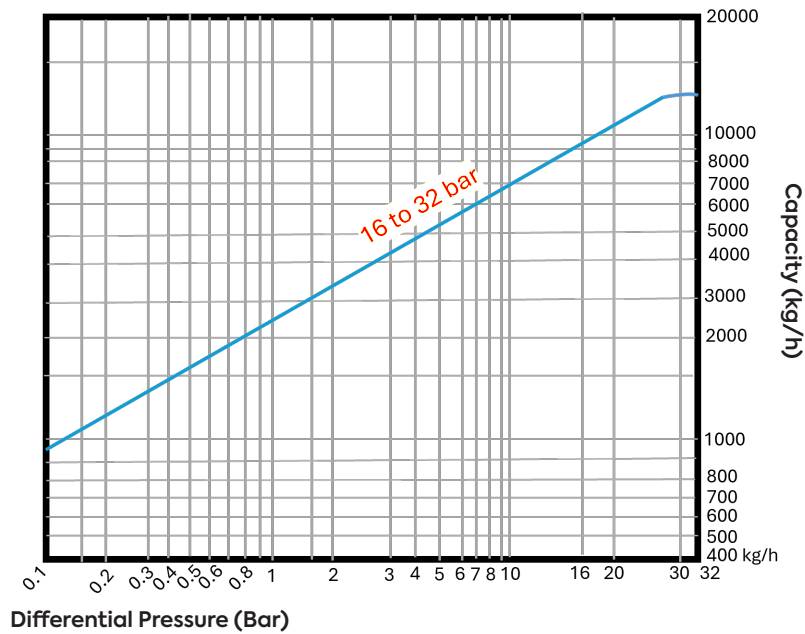

Part Name	Material
Bonnet	WCB
Body	WCB
Seat	420
Disc	420
Other Internal Parts	304

Data Size Table

Connection	Size	L(mm)	H(mm)	H1(mm)	W(mm)	Weight(kg)
Flanged	DN32	230	265	122	340	27
	DN40	230	265	122	340	27.5

ST60.6 | Max Capacity = 23000 kg/h

Technical Parameters	
Nominal pressure	PN40
Max. allowable pressure (Shell)	39.2 Bar / 200°C
Max. allowable temperature (Shell)	450°C / 16.6 Bar
Factory steam action test	>3 times / 16 Bar

Technical Parameters	
Max. operating pressure	32 Bar
Max. operating temperature	350°C
Factory cold test pressure	60 Bar
Air test	20 Bar

Displacement Curve

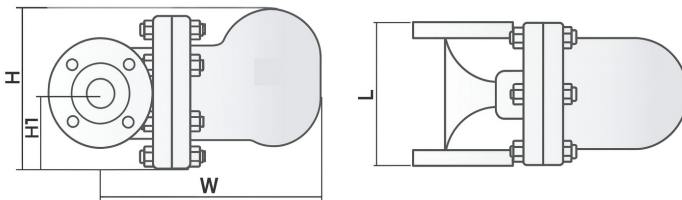
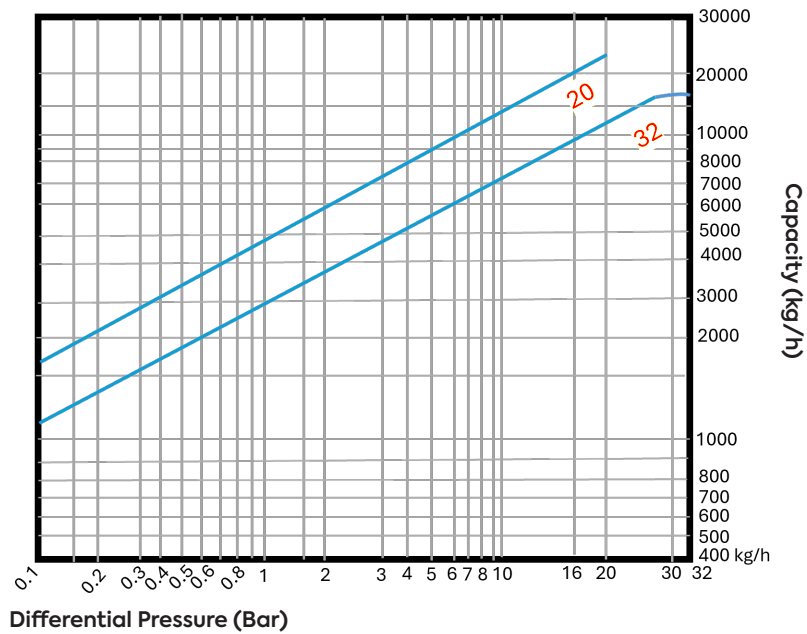

Part Name	Material
Bonnet	WCB
Body	WCB
Seat	420
Disc	420
Other Internal Parts	304

Data Size Table

Connection	Size	L(mm)	H(mm)	H1(mm)	W(mm)	Weight(kg)
Flanged	DN32	230	266	125	360	31
	DN40	230	266	125	360	32
	DN50	230	266	125	360	33

ST60.7 | Max Capacity = 20000 kg/h

Technical Parameters	
Nominal pressure	PN100
Max. allowable pressure (Shell)	98 Bar / 200°C
Max. allowable temperature (Shell)	450°C / 72.9 Bar
Factory steam action test	>3 times / 16 Bar

Technical Parameters	
Max. operating pressure	60 Bar
Max. operating temperature	425°C
Factory cold test pressure	150 Bar
Air test	20 Bar

Displacement Curve

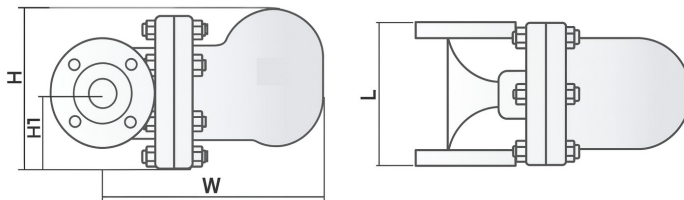
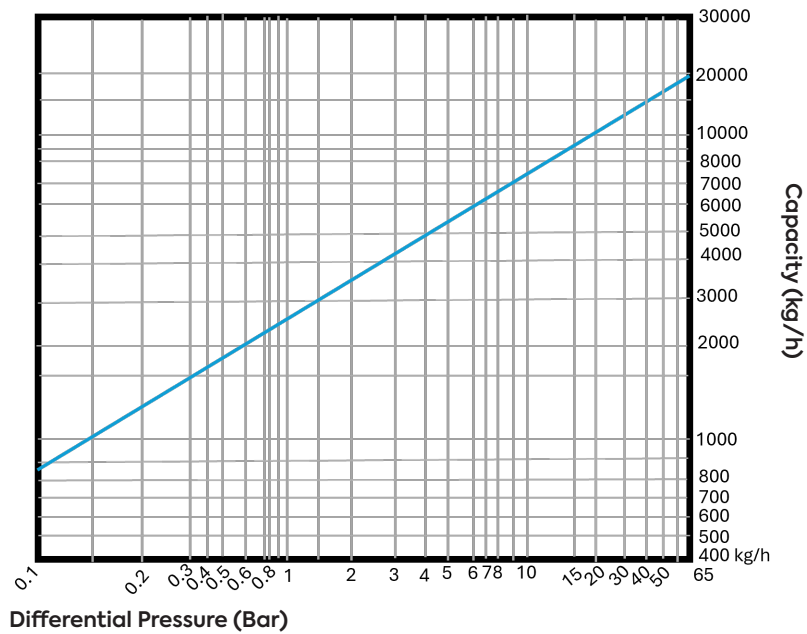

Part Name	Material
Bonnet	WC6
Body	WC6
Seat	420
Disc	420
Other Internal Parts	304

Data Size Table

Connection	Size	L(mm)	H(mm)	H1(mm)	W(mm)	Weight(kg)
Flanged	DN50	330	267	114	378	41
	DN65	350	267	114	378	42
	DN80	350	267	114	378	45

ST60.8 | Max Capacity = 50000 kg/h

Technical Parameters	
Nominal pressure	PN40
Max. allowable pressure (Shell)	39.2 Bar / 200°C
Max. allowable temperature (Shell)	450°C / 16.6 Bar
Factory steam action test	>3 times / 16 Bar

Technical Parameters	
Max. operating pressure	32 Bar
Max. operating temperature	350°C
Factory cold test pressure	60 Bar
Air test	20 Bar

Displacement Curve

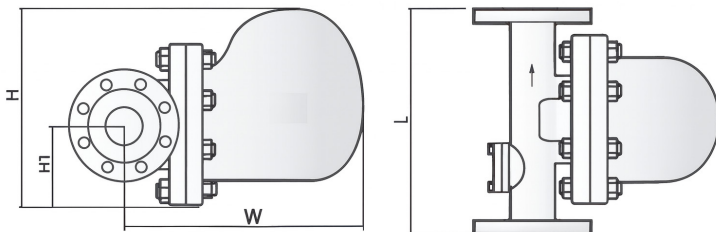
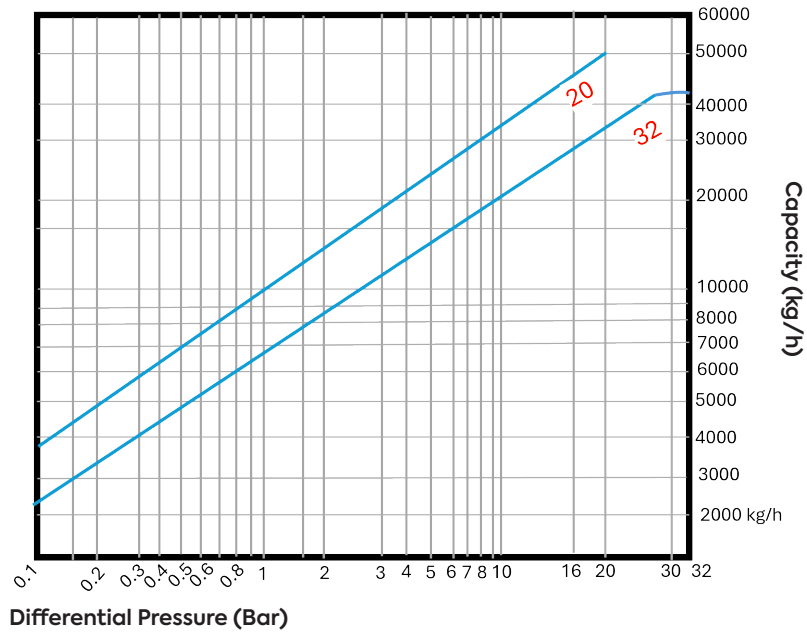

Part Name	Material
Bonnet	WCB
Body	WCB
Seat	420
Disc	420
Other Internal Parts	304

Data Size Table

Connection	Size	L(mm)	H(mm)	H1(mm)	W(mm)	Weight(kg)
Flanged	DN50	380	345	135	385	53
	DN65	380	345	135	385	54
	DN80	380	345	135	385	56

ST60.9 | Max Capacity = 140 T/h

Technical Parameters	
Nominal pressure	PN40
Max. allowable pressure (Shell)	39.2 Bar / 200°C
Max. allowable temperature (Shell)	450°C / 16.6 Bar
Factory steam action test	>3 times / 16 Bar

Technical Parameters	
Max. operating pressure	32 Bar
Max. operating temperature	350°C
Factory cold test pressure	60 Bar
Air test	20 Bar

Displacement Curve

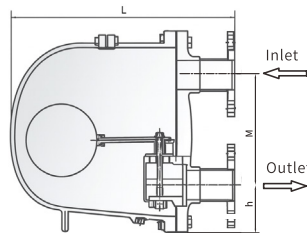
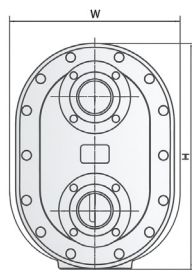
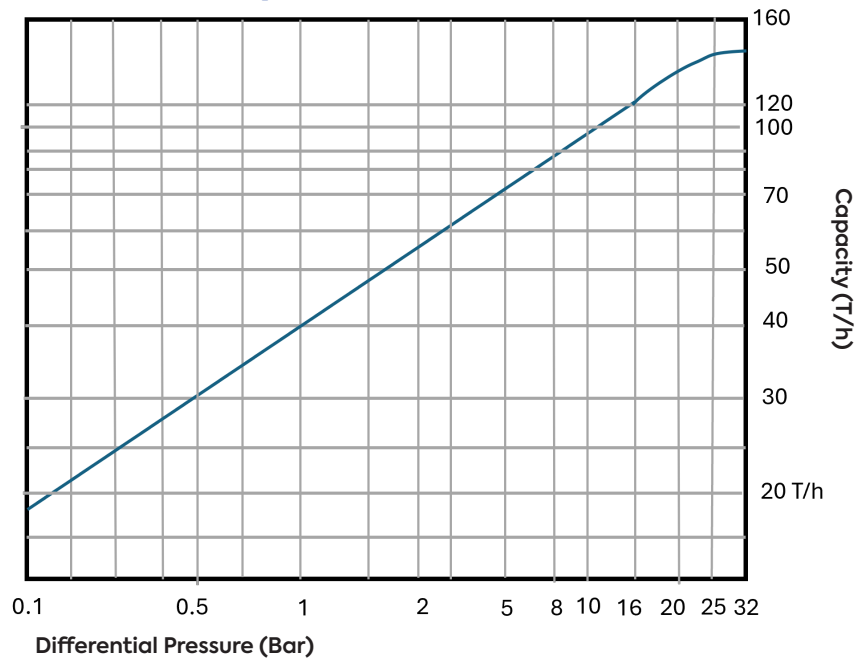

Part Name	Material
Bonnet	WCB
Body	WCB
Seat	420
Disc	420
Other Internal Parts	304

Data Size Table

Connection	Size	L(mm)	H(mm)	W(mm)	h(mm)	M(mm)	Weight(kg)
Flanged	DN80	570	538	335	135	287	138
	DN100	590	538	335	135	287	145
	DN150	630	538	335	135	287	150

THERMODYNAMIC STEAM TRAP

Thermodynamic steam traps are commonly used in low, medium, and high-pressure steam delivery systems, process heat tracing, and small displacement equipment. They are valued for their Compact size, high discharge capacity, energy efficiency, long service life, and excellent resistance to low temperatures.

The technical strengths of ValveWerkz thermodynamic traps lie in their well-engineered construction and precision internal components.

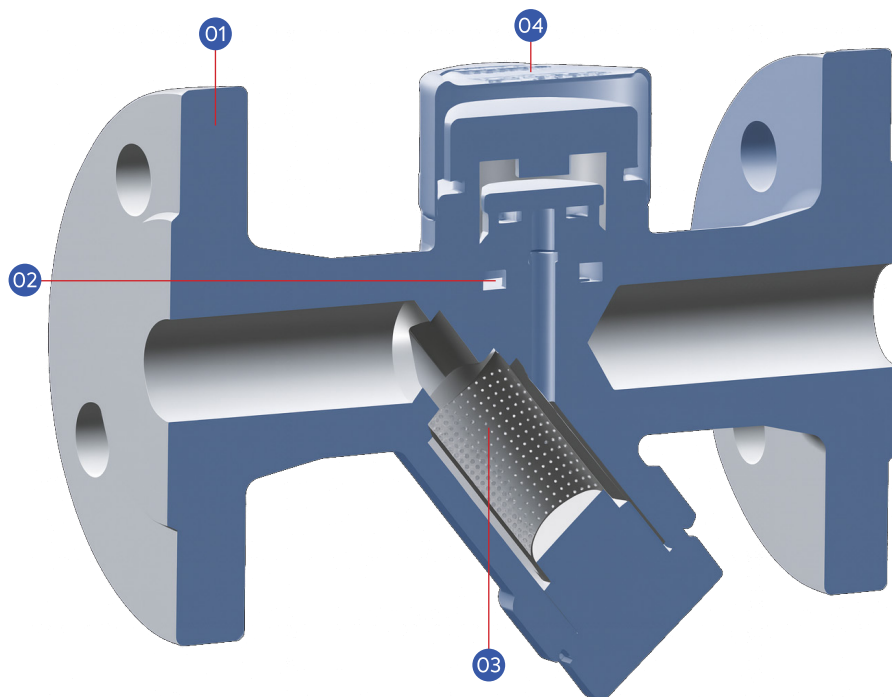

1. High-Strength Corrosion Resistance

Manufactured using A105 or 15CrMo materials, with careful consideration given to corrosion allowance, shell wall thickness, and temperature rating in the design process.

2. Precision Valve Seat and Disc

The valve seat and disc are made from martensitic stainless steel. Specialised heat treatment enables effective condensate removal and minimises flash steam, tailored to various operating conditions.

3. Integrated Filtering Device

Prevents pipeline impurities from entering the valve, ensuring consistent and reliable trap performance.

4. Stainless Steel Insulation Cover

The stainless steel cover protects the internal chamber from outdoor environmental conditions, reducing the risk of malfunctions or mechanical instability due to external factors.

Structural Features

ValveWerkz thermodynamic steam trap use A105 material for low-pressure valve bodies, while 15CrMo is used for medium-pressure variants.

Based on Bernoulli's equation, and following extensive testing and calculation, each trap is optimised to support either low-temperature or saturated condensate discharge:

- The low-temperature type discharges condensate at lower temperatures (with greater subcooling). It operates with minimal noise but has limited air discharge capacity.
- The saturated type discharges condensate close to saturation temperature (with minimal subcooling). It offers better air discharge capability but operates with higher noise levels.

Thermodynamic steam traps function by responding to the flow rate difference between steam and condensate. When condensate passes through the valve seat, the low flow rate causes the valve plate to open and discharge the water. As steam enters, the high flow rate forces the valve seat to close.

The low-temperature type uses flash steam to assist in valve closure. ValveWerkz addresses the common drawbacks of conventional thermal traps, such as energy inefficiency, noise, and steam leakage, by offering a Compact, low-noise solution with long service life, reliable operation, and minimal maintenance requirements. The design ensures no original steam leakage, particularly in the low-temperature model.

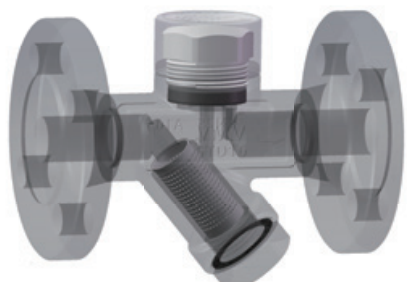

Material and Performance Specifications

The body and bonnet of the thermodynamic steam trap are made from ASTM A105 (15CrMo), with internal components made of stainless steel and an integrated filter.

- Nominal pressure: PN25 / PN63
- Maximum allowable temperature: 425°C
- Maximum working pressure: 16 to 42 Bar
- Maximum working temperature: 400 to 425°C
- Connection options: Threaded RC or flange (GB/T9115.1-2000; HG/T20515-2009; HG/T20592-2009, etc.)

Selection and Installation

Thermodynamic steam traps are intermittent drainage. Normally, orifice of 16 bar have a subcooling degree of 5-10°C, and orifice of 42 bar has a subcooling degree of 20-50°C. If there is a requirement for subcooling, indicate when ordering. The back pressure rate of thermodynamic traps can reach $\geq 80\%$ (back-end pipeline pressure/steam pressure), which is suitable for pipelines and small equipment to remove condensate. In general, the safety factor is 2-3 times.

Warm reminder: The condensed water volume and pressure difference of steam equipment are important indicators for type selection.

Note

The volume of condensate and the pressure differential in your steam system are key factors when selecting the appropriate trap type.

Valve Body Pressure - Rating Temperature (25 Bar; WCB)

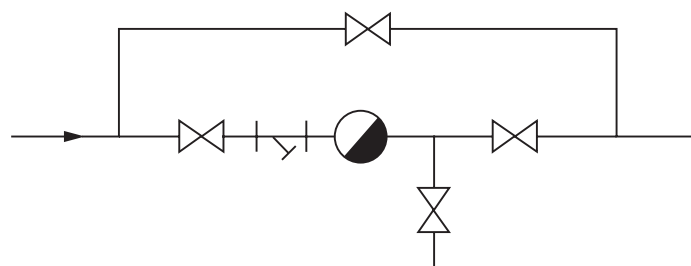
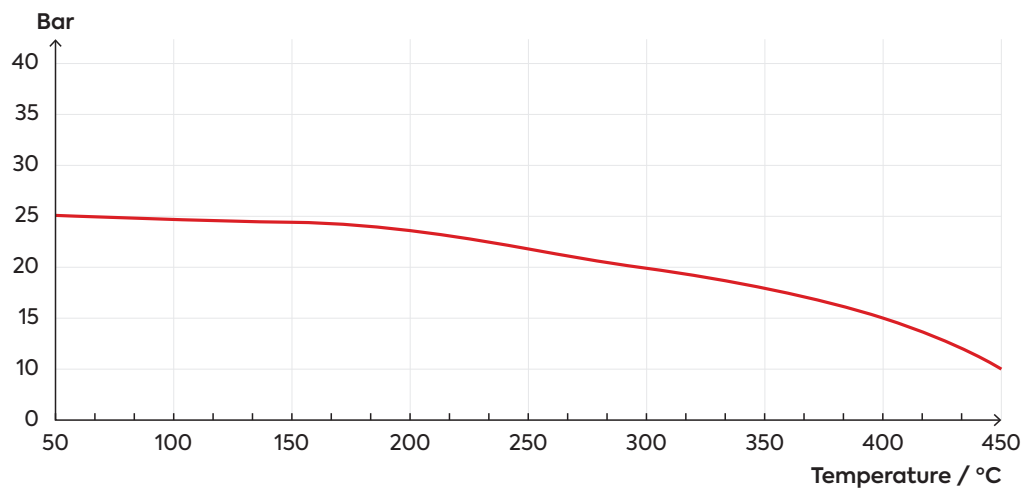

The displacement capacity of a steam trap increases with rising pressure difference. Please refer to the displacement curve for accurate sizing. Do not confuse this with a large-diameter trap, which may have a different displacement profile.



ST61 Series Thermodynamic Steam Trap

Carbon Steel
SS304

SS304

Threaded End
Socket Weld End
Flanged End

DN15 (1/2") to DN25 (1")

Max Discharge = 800 kg/hr

PN25 - PN63

Max W.P = 16 Bar, 42 Bar

ST61

Nominal pressure	PN25	PN63
Max. allowable pressure (Shell)	24.5 Bar / 200°C	62.7 Bar / 200°C
Max. allowable temperature (Shell)	450°C / 10.3 Bar	450°C / 26.7 Bar
Factory steam action test	>3 times / 16 Bar	>3 times / 16 Bar

Nominal pressure	PN25	PN63
Max. operating pressure	16 Bar	42 Bar
Max. operating temperature	350°C	350°C
Factory cold test pressure	38 Bar	95 Bar
Air test	20 Bar	20 Bar

Displacement Curve

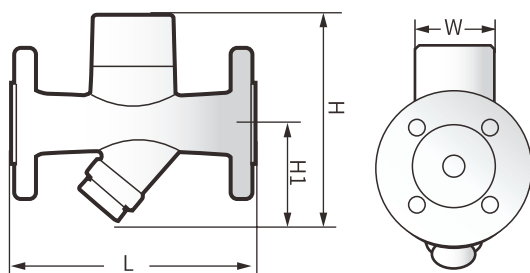
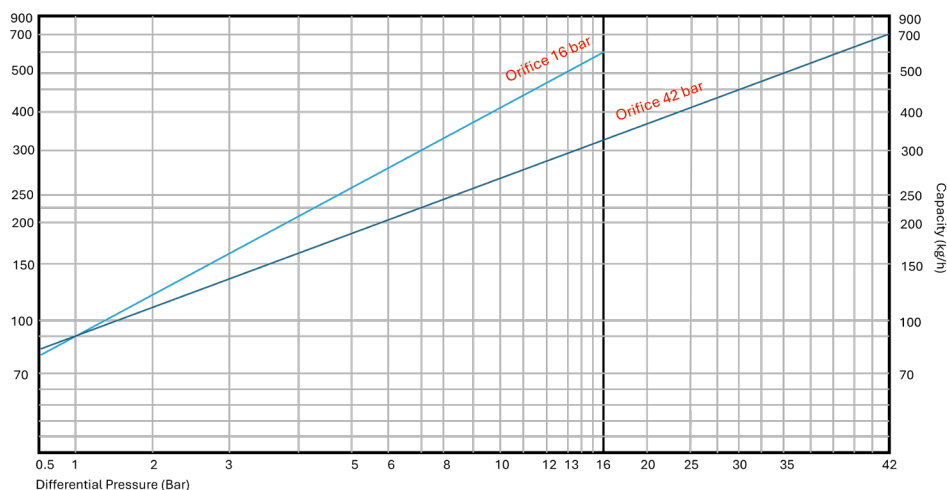

Part Name	Material
Bonnet	A105 / F304 / F316
Body	A105 / F304 / F316
Seat	440C
Disc	440C
Other Internal Parts	304

Data Size Table

Connection	Size	L(mm)	H(mm)	H1(mm)	W(mm)	Weight(kg)
Threaded	DN15 - 25	90	120	68	48	1/1.5
Butt Weld / Socket Weld	DN15 - 25	90	120	68	48	1/1.5
Flanged	DN15 - 25	150	120	68	48	2.5 - 3

BIMETALLIC STEAM TRAP

Bimetallic steam traps offer high subcooling capability, long service life, excellent energy efficiency, strong resistance to water hammer, and a clean, Compact design. They are commonly used in heating systems and steam transportation pipelines.

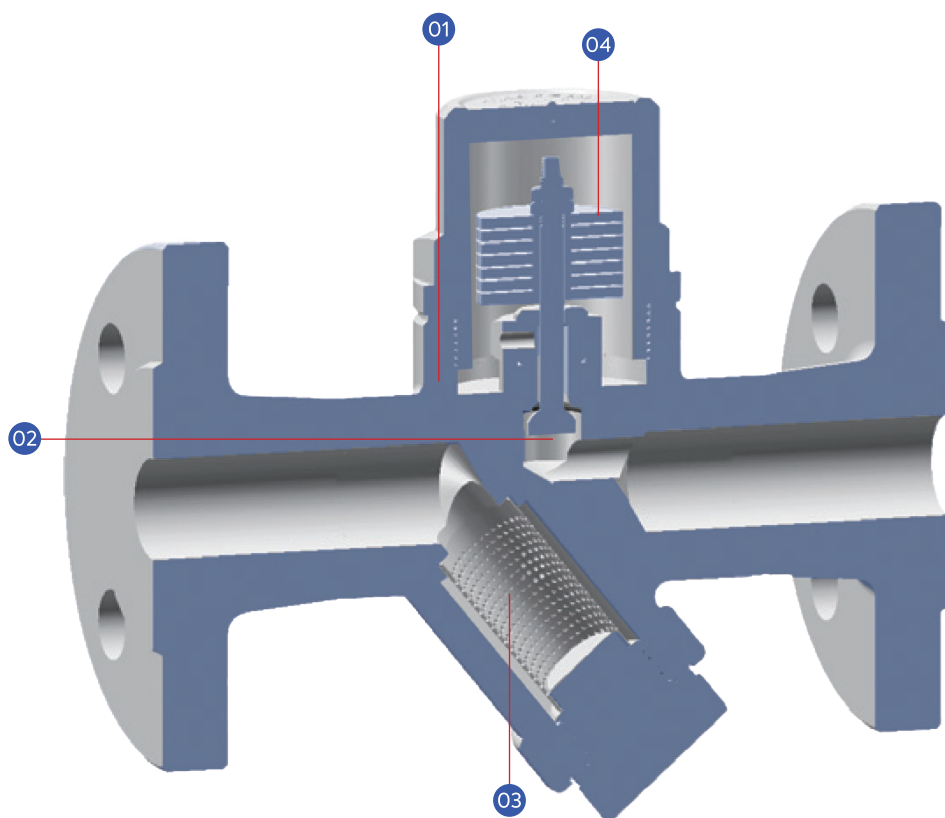

1. High-Strength Corrosion Resistance

Constructed with A105 material, the design takes into account corrosion allowance, shell wall thickness, pressure, and temperature ratings for long-term durability.

2. Linear Sealing Closure System

The trap features a unique linear sealing mechanism with a micron-level precision valve seat and core, ensuring reliable closure and effective steam sealing.

3. Built-in Filtering Device

Prevents pipeline impurities from entering the valve, supports consistent operation, and protects internal components from water hammer damage.

4. Imported Bimetal

Uses high-quality bimetallic sheets imported from the U.S. to ensure accurate bending performance, adjustable temperature control, and precise thermal response.

Structural Features

The body and bonnet of the ValveWerkz bimetallic steam trap are made from A105 material. The condensate discharge temperature is adjustable and is factory-set between 120°C and 130°C.

This steam trap uses a line-sealed shut-off system that eliminates original steam leakage and noise. It offers excellent air discharge capability, maximises the sensible heat of condensate water, and provides strong energy-saving performance.

The bimetallic steam trap operates based on the temperature difference between steam and condensate. When condensate remains in the pipeline due to high temperature, the energy to be released gradually lowers. As the temperature drops, the bimetal deforms, causing the valve seat to open and discharge the condensate.

Users can manually adjust the discharge temperature of the trap to suit seasonal conditions and operational requirements.

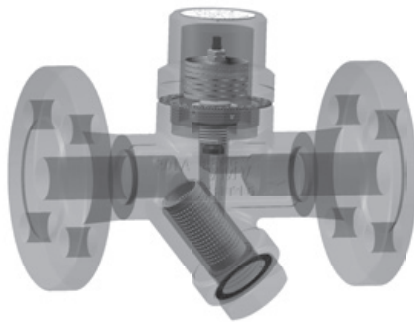

Material and Performance Specifications

The body and bonnet of the bimetallic steam trap are made from ASTM A105. The bimetal element is manufactured from imported materials, and all internal components are made of stainless steel with an integrated filtering device

- Nominal pressure: PN25 / PN40
- Maximum allowable temperature: 400°C
- Maximum working pressure: 16 to 23 Bar
- Maximum working temperature: 375 to 400°C
- Connection options: Threaded RC or flange (GJB7/1915.1–2000; HG/T20615–2009; HG/T20592–2009, etc.)

Selection and Installation

Thermodynamic steam traps operate with intermittent drainage. The orifice of 16 bar typically features a subcooling range of 5–10°C, while the orifice of 42 bar supports a wider range of 20–50°C. If subcooling is required for your application, please specify this during the ordering process.

These traps can achieve a back pressure ratio of 80% or more (ratio of back-end pipeline pressure to steam pressure), making them well-suited for pipelines and Compact equipment where condensate removal is essential.

As a general guideline, a safety factor of 2 to 3 times is recommended when selecting trap models.

Note

The volume of condensate and the pressure differential in your steam system are key factors when selecting the appropriate trap type.

Valve Body Pressure - Rating Temperature (25 Bar; WCB)

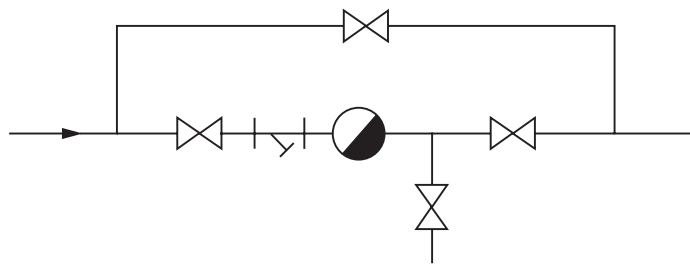
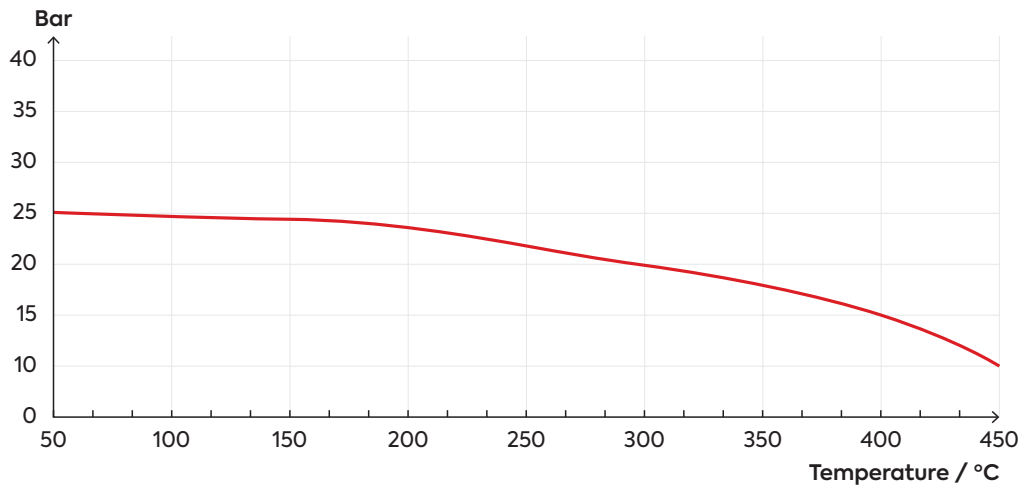

The displacement capacity of a steam trap increases as the pressure difference rises. Please refer to the displacement curve for accurate selection. Do not confuse this with a large-diameter trap, which may not offer the same displacement characteristics.



ST62 Series Bimetallic Steam Trap

Carbon Steel
SS304

SS304

Threaded End
Socket Weld End
Flanged End

DN15 (½") to DN25 (1")

Max Discharge = 800 kg/hr

PN25 - PN40

Max W.P = 21 - 32 Bar

**ST62.1 |
Max Capacity
= 800 kg/h**

Technical Parameters	
Nominal pressure	PN25
Max. allowable pressure (Shell)	24.5 Bar / 200°C
Max. allowable temperature (Shell)	450°C / 10.3 Bar
Factory steam action test	>3 times / 16 Bar

Technical Parameters	
Max. operating pressure	16 Bar
Max. operating temperature	350°C
Factory cold test pressure	38 Bar
Air test	20 Bar

Temperature Adjustment Table

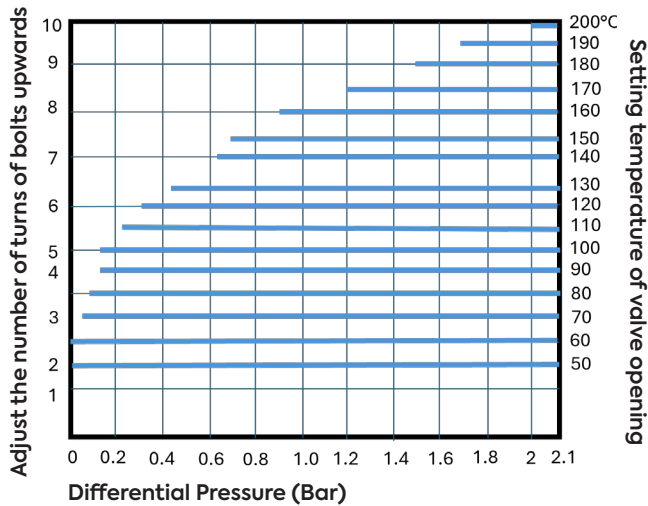

Displacement Curve

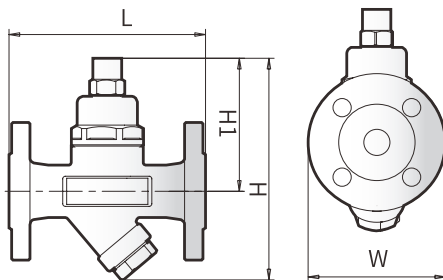
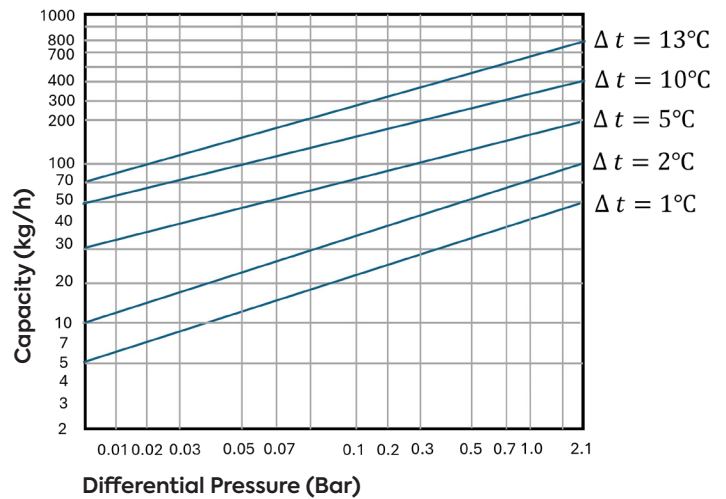

Part Name	Material
Bonnet	A105 / F304 / F316
Body	A105 / F304 / F316
Seat	420
Disc	440C + 304
Other Internal Parts	304

Data Size Table

Connection	Size	L(mm)	H(mm)	H1(mm)	W(mm)	Weight(kg)
Threaded	DN15 - 25	90	168	100	55	1.8
Butt Weld / Socket Weld	DN15 - 25	90	168	100	55	1.8
Flanged	DN15 - 25	150	168	100	115	4

ST62.2 | Max Capacity = 750 kg/h

Technical Parameters	
Nominal pressure	PN40
Max. allowable pressure (Shell)	48 Bar / 300°C
Max. allowable temperature (Shell)	427°C / 32 Bar
Factory steam action test	>3 times / 16 Bar

Technical Parameters	
Max. operating pressure	32 Bar
Max. operating temperature	350°C
Factory cold test pressure	95 Bar
Air test	20 Bar

Temperature Adjustment Table

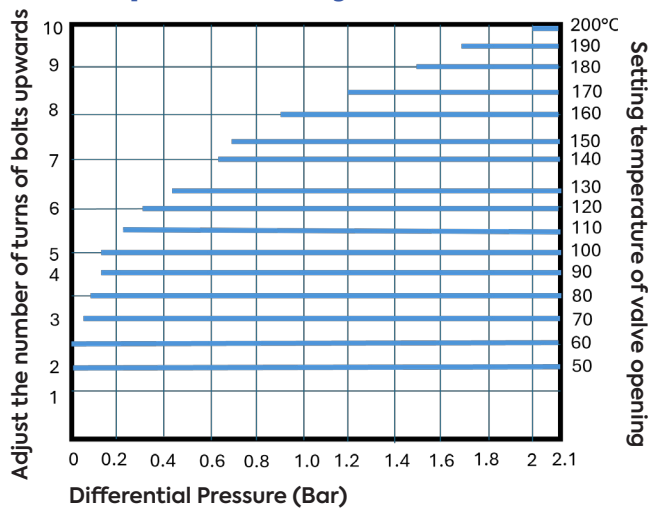

Displacement Curve

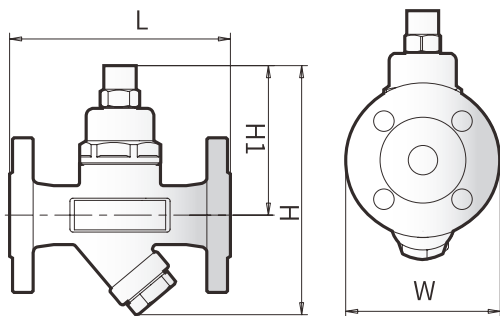
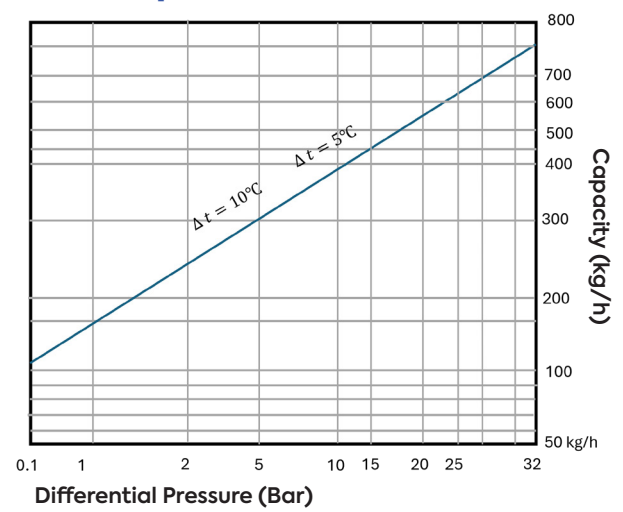

Part Name	Material
Bonnet	A105 / F304 / F316
Body	A105 / F304 / F316
Seat	420
Disc	440C + 304
Other Internal Part	304

Data Size Table

Connection	Size	L(mm)	H(mm)	H1(mm)	W(mm)	Weight(kg)
Threaded	DN15 - 25	90	168	100	55	1.8
Butt Weld / Socket Weld	DN15 - 25	90	168	100	55	1.8
Flanged	DN15 - 25	150	168	100	115	4

THERMOSTATIC (CAPSULE) STEAM TRAP

Thermostatic (Capsule) steam traps are commonly used in heat tracing pipelines and equipment requiring small displacement and low-temperature operation. Their Compact design, large subcooling capability, strong energy-saving performance, and excellent resistance to low temperatures make them ideal for such applications.

The technical advantages of ValveWerkz traps lie in their precise internal components and well-engineered construction.

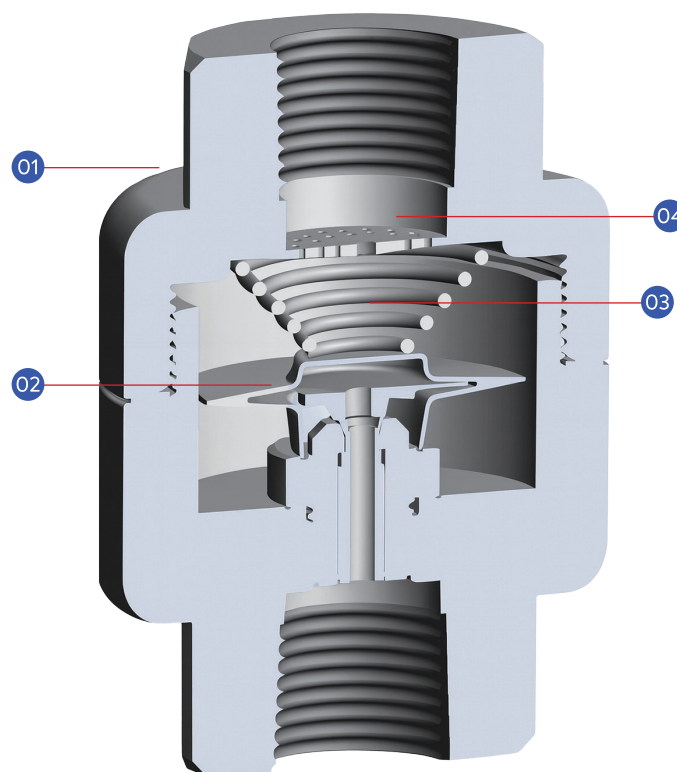

1. High Strength Corrosion Resistance

Constructed from SS304 stainless steel, offering excellent corrosion resistance along with a polished, hygienic appearance.

2. Large Subcooling Capsule Module

Designed with a subcooling range of 15°C, the capsule trap effectively removes condensate below the saturation temperature, ensuring high energy efficiency.

3. Suitable for Clean Applications

All internal components are made from 304 stainless steel, making this trap suitable for use in food, pharmaceutical, and other sanitary industries.

4. Integrated Filtration Design

Built-in filtration prevents pipeline impurities from entering the valve, ensuring consistent and reliable operation.

Structural Features

ValveWerkz capsule steam trap uses a valve body and cover made from 304 stainless steel, making it suitable for clean environments such as medical, sanitation, food, and pharmaceutical industries. The trap operates with a condensate discharge temperature range of 15–20°C.

It features a face-sealed closure system that is noiseless, provides excellent air exhaust capability, and maximises the sensible heat of condensate for improved energy efficiency.

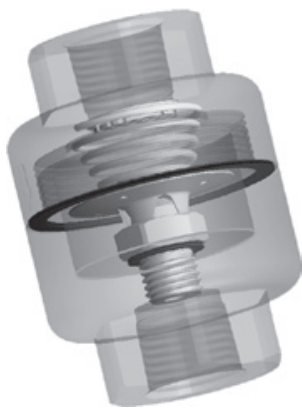

The capsule steam trap works based on the temperature difference between steam and condensate. When high pipeline temperatures prevent immediate condensate discharge, the diaphragm inside the trap responds by opening the valve seat as the heat energy decreases, allowing the condensate to be expelled.

Additionally, the capsule steam trap can function as an air exhaust valve.

Material and Performance Specifications

The body of the capsule steam trap is made from 304 stainless steel. The internal components, including the capsule, are also constructed from stainless steel. The inlet is equipped with a built-in filter to ensure clean operation.

- Nominal pressure: PN25
- Maximum allowable temperature: 400°C
- Maximum working pressure: 16 Bar
- Maximum working temperature: 400°C
- Connection options: Threaded RC or flange (GB/T9115.1–2000; HG/T20615–2009; HG/T20592–2009, etc.)

Selection and Installation

The bellows-type capsule steam trap provides continuous drainage. Standard models are factory-set to discharge at a subcooling range of 15–20°C. If a specific subcooling requirement is needed, please indicate this when placing your order.

The back pressure ratio of the bellows trap can reach up to 50% (back-end pipeline pressure to steam pressure). While not suitable for closed recovery systems, it is ideal for pipelines and heating systems used for condensate removal.

As a general rule, a safety factor of 2 to 3 times is recommended during model selection.

Important

The condensate volume and pressure differential of your steam system are key factors when selecting the appropriate trap. Displacement increases as pressure difference rises. Always refer to the displacement curve for accurate sizing.

Do not confuse high displacement capability with a large-diameter trap.

Valve Body Pressure - Rating Temperature (25 Bar; SS 304)

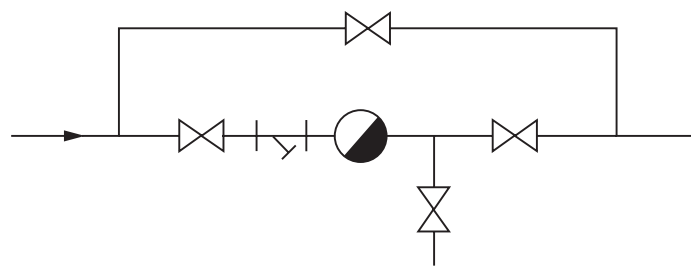
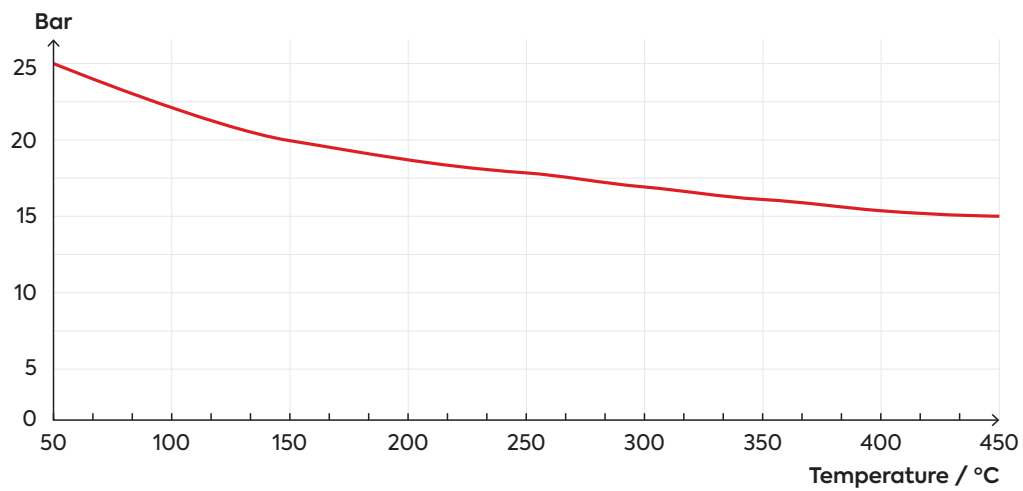

The capsule steam trap can be installed at any position within the pipeline or equipment as required. The diagram above illustrates the standard configuration for correct installation.

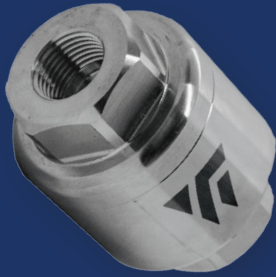

ST63 Series

Thermostatic (Capsule) Steam Trap

- SS304
- SS316
- Threaded End
- Flanged End
- DN15 (½") to DN25 (1")
- Max Discharge = 300 kg/hr
- PN25
- Max W.P = 16 Bar

Displacement Curve

Technical Parameters	
Nominal pressure	PN25
Max. allowable pressure (Shell)	16 Bar / 250°C
Max. allowable temperature (Shell)	350°C / 14.6 Bar
Factory steam action test	>3 times / 16 Bar
Max. operating pressure	16 Bar
Max. operating temperature	204°C
Factory cold test pressure	38 Bar
Air test	6 Bar

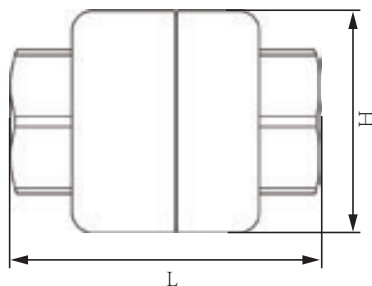
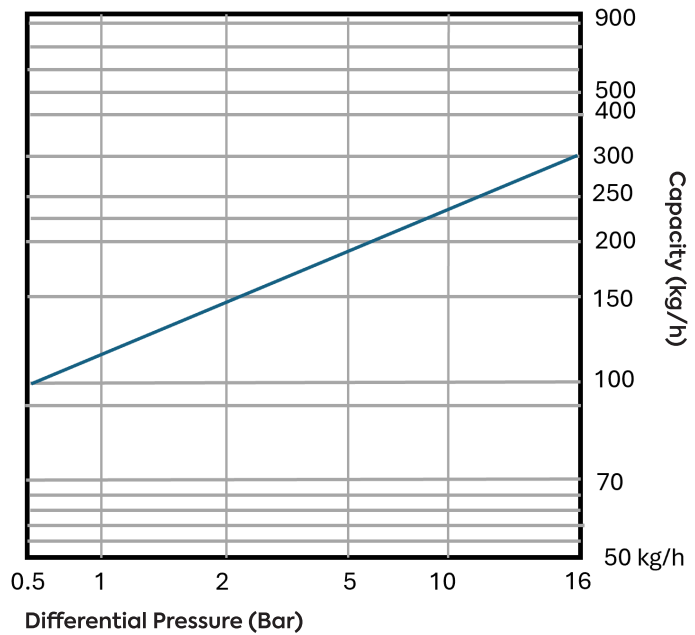

Part Name	Material
Bonnet	SS304 / SS316
Body	SS304 / SS316
Seat	420
Valve Core	304
Other Internal Parts	304

Data Size Table

Connection	Size	L(mm)	H(mm)	Weight(kg)
Threaded	DN15 - 20	75	55	1
Butt Weld / Socket Weld	DN25	80	55	1.2
Flanged	DN15 - 25	120	125	3.8

REQUEST FOR QUOTE



STEP 1

Find the model series



STEP 2

Define the specification/ valve code



STEP 3

Fill up ordering sheet (back of the brochure) or Scan the QR code below



STEP 4

Submit your order via our website or contact your local partner



STEP 5

Prepare for confirmation and delivery

*For further assistance with placing your order, please contact your local partner. A sales engineer will be assigned to assist you.

Valve Coding Sheet Thermostatic (Capsule) Steam Trap

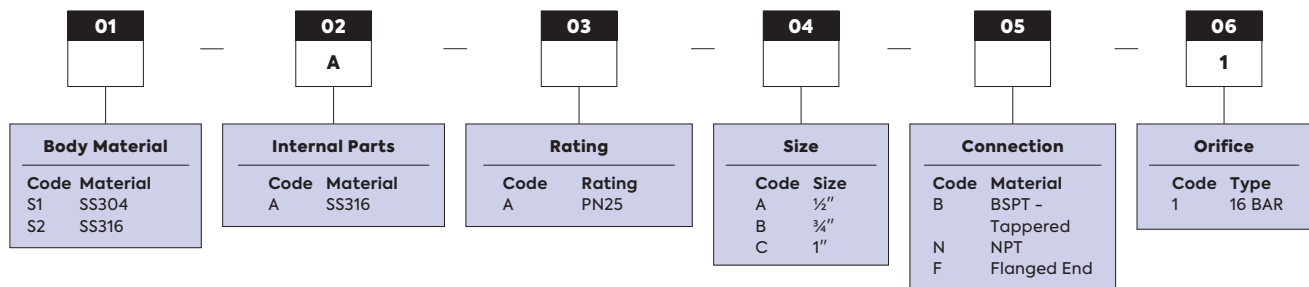

Your Valve Ordering Code:

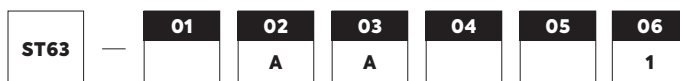

Example:

ST63 - S1AABB1.
SS304 Body Material. SS316 Internal Parts. Pressure Rating of PN25, ½ inch size. Connection Type of BSPT - Tapped. Orifice 16 BAR.

*For special material or customisation, please refer to our sales engineer.



SCAN FOR ONLINE ORDERING FORM

Tel: +65 6909 1221
Email: enquiry@valvewerkz.com
Website: www.valvewerkz.com