

# ROTARY GLOBE CONTROL VALVE



# ROTARY GLOBE CONTROL VALVE

The Rotary Globe Control Valve combines the control performance of globe valves with the compact size and low friction of rotary valves. Its eccentric plug design minimises wear during throttling and generates additional seating force at closure, providing low leakage and reliable shut-off with reduced actuator requirements. The valve is suitable for chemical, metallurgical, power generation, and general industrial process control applications.



## 1. Integrated Body and Bonnet Construction

One-piece cast body with integral bonnet eliminates static pressure boundary joints. The only dynamic sealing point is at the shaft, reducing potential leakage paths and improving long-term reliability.

## 2. Eccentric Plug Geometry with Progressive Seating Action

The eccentric structure prevents separation instability between the plug and seat during operation and ensures stable engagement at valve closure.

## 3. High Flow Capacity with Wide Control Range

Optimised internal flow path provides high flow capacity and wide rangeability, suitable for heavy-duty industrial service.

## 4. Optional Pressure Reduction via Multi-Hole Plate

Pressure drop can be reduced by installing a multi-hole plate within the valve body to improve flow stability and mitigate flashing or cavitation.

## 5. Flexible Multi-Hole Plate Configurations

Multi-hole plates are available in both integrated internal and combined external configurations to suit different process requirements.

### 6. Options for Crystallising and Erosive Media

Heat jacket construction and erosion-resistant surface treatment are available for services involving crystallisation or abrasive fluids.

### 7. Simplified Maintenance and Component Replacement

Symmetrical rotary plug design allows easy replacement of internal components and actuators without special orientation requirements.

### 8. Tight Shut-Off Performance Options

Metal seat construction provides ANSI Class IV or Class V shut-off, while soft seat construction achieves ANSI Class VI shut-off.

## Model Indication

RG	XX	X	X	0	X
Valve	Actuator	Installation type of actuator	Valve Trim	Design Code	Body Type
Rotary Valve	60 Spring return rolling diaphragm	1, Parallel to pipe - Air to close	M Metal seat	0	O: Standard J: Jacket type
		2, Parallel to pipe - Air to open			
		3, Vertical to pipe - Air to close			
		4, Vertical to pipe - Air to open			
	70 Double acting piston type	5, Parallel to pipe - Air to close	S Soft seat		
		6, Parallel to pipe - Air to open			
		7, Vertical to pipe - Air to close			
		8, Vertical to pipe - Air to open			

# ACTUATOR MOUNTING GUIDE

RG	01	02	03	04	05	06	07	08
	S2	60		M	A	F1	T	P

Actuator Position in Relation to Valve Body  
Numbering System: 1 to 8

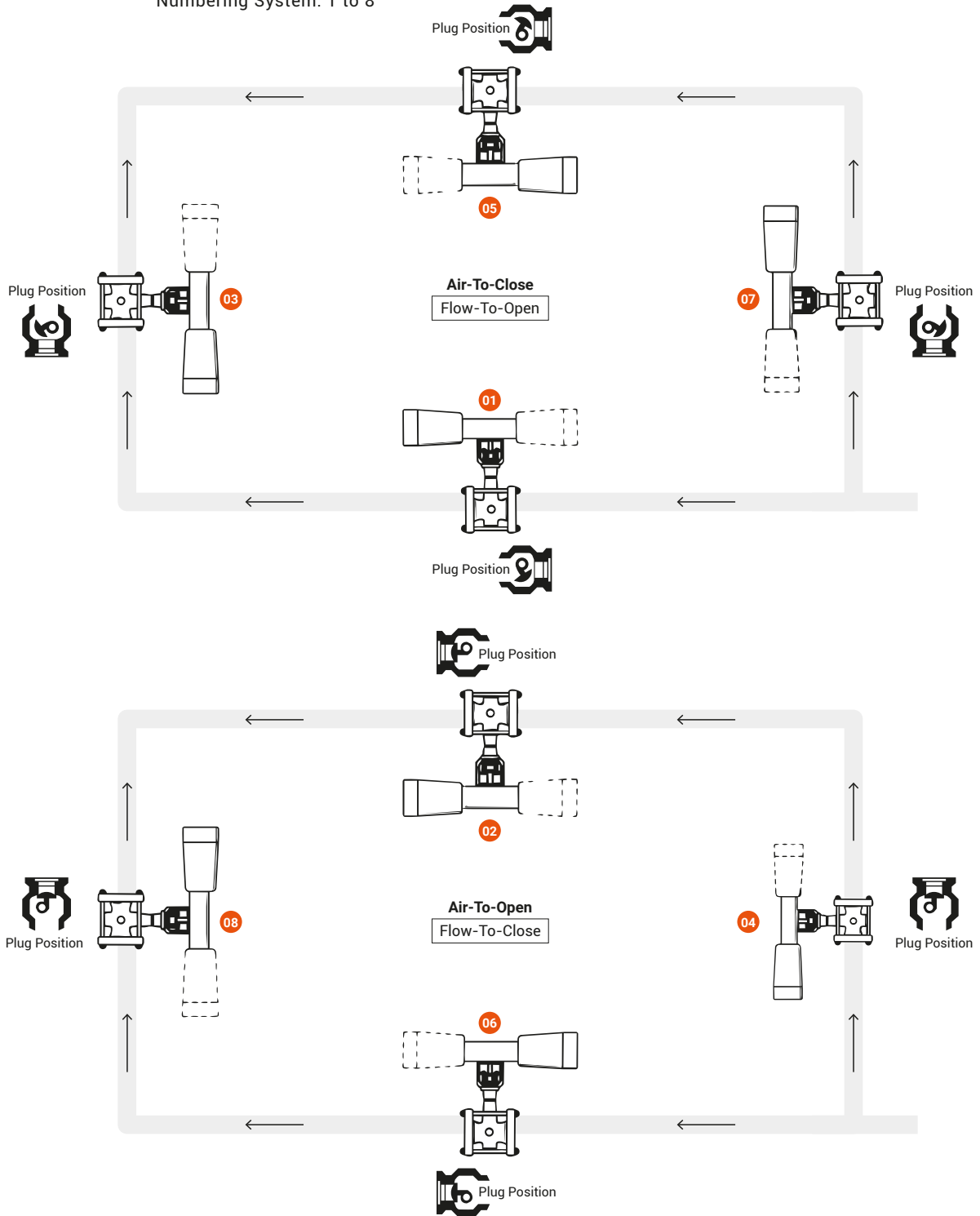

\*Specify the required valve and actuator orientation by selecting the corresponding position number in the ordering sheet.

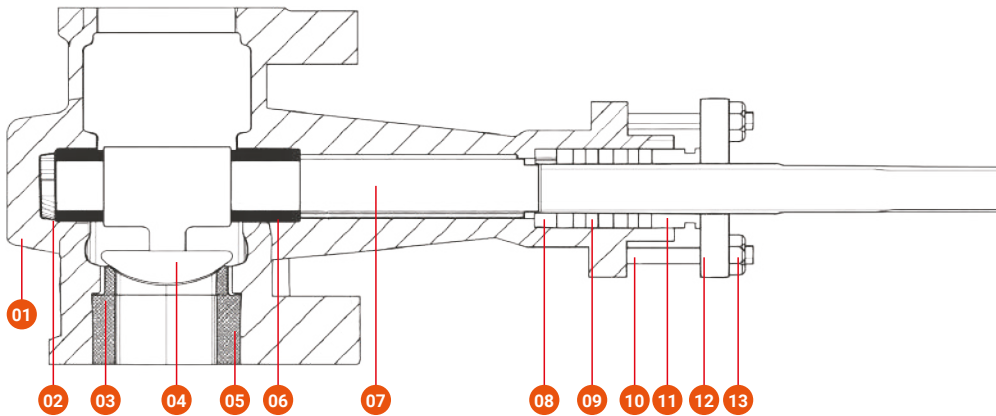
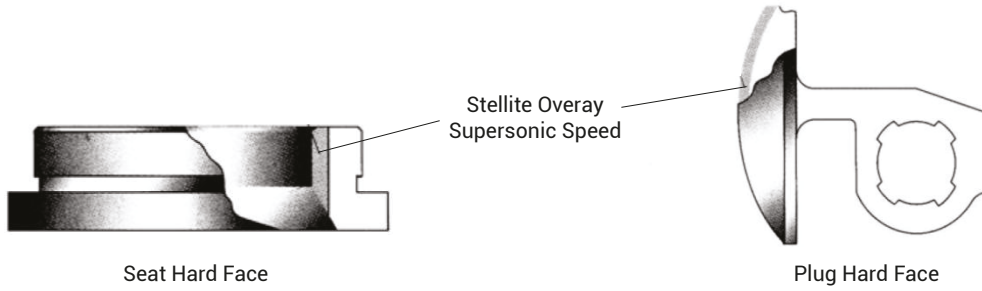

Part Name	Material
1. Body	WCB / SS316
2. Down Sleeve	SUS316+ST
3. Seat	SUS316+ST
4. Plug	SUS316+ST
5. Compressed Bolt	SUS316+ST
6. Up Sleeve	SUS316+ST
7. Stem	SUS316

Part Name	Material
8. Gasket	1Cr18Ni9
9. Packing	PTFE / Graphite
10. Packing Stud	1Cr18Ni9
11. Packing Gland	1Cr18Ni9
12. Gland	WCB / SS304
13. Nut	1Cr18Ni9

## Flow Characteristic

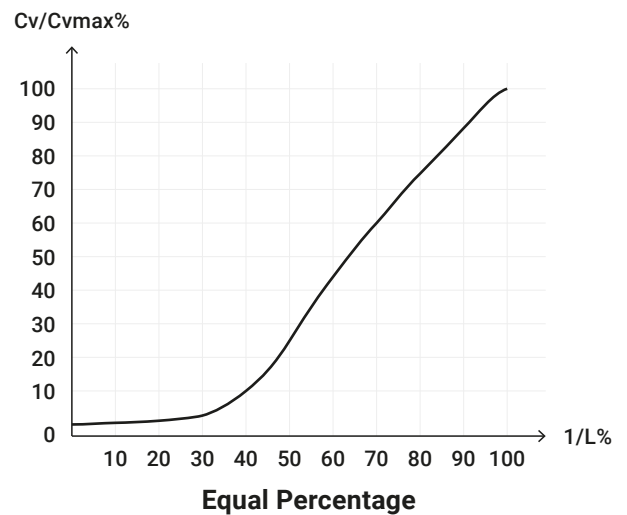
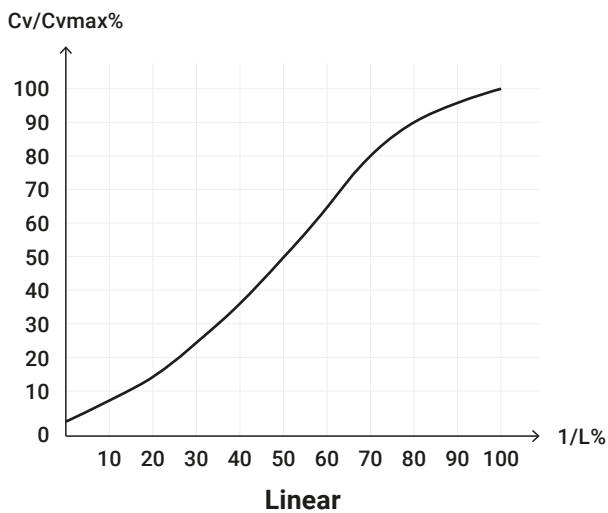

## Basic Tech Data

Size		1"	1½"	2"	3"	4"	6"	8"	10"	12"
Cv		14	30	50	135	230	500	850	1300	1750
		8.4	18	30	81	138	300	510	780	1050
		5.6	12	20	54	92	200	340	520	700
Flow Characteristic		Linear, Equal Percentage								
Pressure		ANSI 150 300 600								
Travel		50°								
Seat Leakage		ANSI B16 104 IV ( Metal ) VI ( Soft )								
Working Temperature		-195~ + 400								
Control Ratio		100 : 1								
Actuator	Diaphragm	DL1 (113)			DL2 (150)		DL3 (175)			

## Pressure drop allowance

Metal seat, Rolling diaphragm actuator ( Spring range 0.5~1.0kgf/cm<sup>2</sup>)

Size Inch	Rated Cv	FTC ATC	FTO ATO	FTO-ATC FTC-ATO Air supply - kgf/cm <sup>2</sup>					
				1.4	1.8	2.1	2.5	2.8	3.2
1	14	70.3	70.3	70.3	-	-	-	-	-
	8.4	101	101	101	-	-	-	-	-
	5.6	101	101	101	-	-	-	-	-
	2.8	101	101	101	-	-	-	-	-
1 - ½	30	34.5	47.1	30.2	56.2	-	-	-	-
	18	52.0	70.3	45.0	96.7	-	-	-	-
	12	70.3	98.4	63.3	101	-	-	-	-
	6	70.3	98.4	63.3	101	-	-	-	-
2	50	19.0	25.3	16.2	35.1	42.3	-	-	-
	30	28.8	39.4	24.6	53.4	70.3	-	-	-
	20	38.0	52.0	33.0	70.3	70.3	-	-	-
	10	38.0	52.0	33.0	70.3	70.3	-	-	-
3	135	14.0	19.7	12.7	26.7	42.2	-	-	-
	81	22.5	29.5	19.0	40.8	65.4	-	-	-
	54	32.3	45.0	28.1	61.2	70.3	-	-	-
4	230	7.0	9.8	6.3	14.0	22.5	31.0	39.4	42.2
	138	11.2	15.5	9.8	21.0	34.5	47.1	60.5	70.3
	92	16.2	21.8	14.0	30.2	49.2	68.2	70.3	70.3

Note: The inlet pressure cannot exceed the allowable value of the rated pressure level of the valve body.

Metal seat, Rolling diaphragm / Cylinder actuator ( Spring range 0.5~1.0kgf/cm2)

Size	Rated Cv	Type Actuator	Flow Direction	FTC ATC	FTO ATO	FTO-ATC FTC-ATO Air supply - kgf/cm2									
						2.1	2.5	2.8	3.2	3.5	3.9	4.2	4.6	5.0	5.3
6	500	60	FTO	-	6.3	3.5	9.1	14.0	21.0	25.3	30.9	36.6	42.2	-	-
			FTC (Gas)	9.8	-	3.5	9.1	14.0	21.0	25.3	30.9	36.6	42.2	-	-
	FTC (Liq.)		9.8	-	3.5	9.1	14.0	21.0	21.0	21.0	21.0	21.0	21.0	-	-
	70	FTO/FTC	-	-	28.1	42.2	-	-	-	-	-	-	-	-	-
	300	60	FTO	-	9.1	4.9	12.6	21.0	28.1	28.1	43.6	51.3	59.8	-	-
			FTC (Gas)	15.4	-	4.9	12.6	21.0	28.1	28.1	43.6	51.3	59.8	-	-
FTC (Liq.)	15.4		-	4.9	12.6	21.0	28.1	28.1	29.9	29.9	59.8	-	-		
70	FTO/FTC	-	-	43.9	61.9	-	-	-	-	-	-	-	-	-	
200	60	FTO	-	14	7.7	19.6	31.6	43.6	43.6	68.2	70.3	-	-	-	
		FTC (Gas)	21.8	-	7.7	19.6	31.6	43.6	43.6	68.2	70.3	-	-	-	
FTC (Liq.)		21.8	-	7.7	19.6	31.6	35.1	35.1	35.1	35.1	-	-	-		
70	FTO/FTC	-	-	61.9	70.3	-	-	-	-	-	-	-	-	-	
8	850	60	FTO	-	3.1	1.7	4.2	7.0	9.8	12.6	15.4	18.3	21.0	24.0	24.6
			FTC (Gas)	4.9	-	1.7	4.2	7.0	9.8	12.6	-	-	-	-	-
	FTC (Liq.)		4.9	-	1.7	4.2	6.3	6.3	6.3	-	-	-	-	-	
	70	FTO/FTC	-	-	15.4	19.7	24.6	-	-	-	-	-	-	-	-
	510	60	FTO	-	4.9	2.8	7.0	11.2	15.4	19.6	23.9	28.1	32.3	-	-
			FTC (Gas)	7.7	-	2.8	7.0	11.2	15.4	19.6	-	-	-	36.6	38.7
FTC (Liq.)	7.7		-	2.8	7.0	9.8	9.8	9.8	-	-	-	-	-		
70	FTO/FTC	-	-	21.8	30.2	38.6	-	-	-	-	-	-	-	-	
340	60	FTO	-	7.7	4.2	11.2	17.6	24.6	31.6	38.6	45.0	52.0	59.0	63.3	
		FTC (Gas)	12.6	-	4.2	11.2	17.6	24.6	31.6	-	-	-	-	-	
FTC (Liq.)		12.6	-	4.2	11.2	15.4	15.4	15.4	-	-	-	-	-		
70	FTO/FTC	-	-	35.1	49.2	63.3	-	-	-	-	-	-	-	-	
10	1300	60	FTO	-	1.7	1.0	2.4	3.8	5.6	7.0	8.4	9.8	11.2	12.6	14.8
			FTC (Gas)	2.8	-	1.0	2.4	3.8	5.6	7.0	-	-	-	-	-
	FTC (Liq.)		2.8	-	1.0	2.4	3.5	3.5	3.5	-	-	-	-	-	
	70	FTO/FTC	-	-	7.7	10.5	14.0	-	-	-	-	-	-	-	
	780	60	FTO	-	2.8	1.4	3.5	5.6	8.4	10.5	12.6	15.4	17.6	19.6	22.5
			FTC (Gas)	4.2	-	1.4	3.5	5.6	8.4	10.5	-	-	-	-	-
FTC (Liq.)	4.2		-	1.4	3.5	4.9	4.9	4.9	-	-	-	-	-		
70	FTO/FTC	-	-	11.9	16.2	21.0	-	-	-	-	-	-	-		
520	60	FTO	-	4.2	2.4	6.3	9.8	13.4	16.9	21.0	24.6	28.1	32.3	37.2	
		FTC (Gas)	7.0	-	2.4	6.3	9.8	13.4	16.9	-	-	-	-	-	
FTC (Liq.)		7.0	-	2.4	6.3	9.8	8.4	8.4	-	-	-	-	-		
70	FTO/FTC	-	-	18.9	26.7	33.7	-	-	-	-	-	-	-		

Size	Rated Cv	Type Actuator	Flow Direction	FTC ATC	FTO ATO	FTO-ATC FTC-ATO Air supply - kgf/cm <sup>2</sup>										
						2.1	2.5	2.8	3.2	3.5	3.9	4.2	4.6	4.9	5.3	
12	1750	60	FTO	-	1.0	-	1.4	2.1	3.2	3.8	4.9	5.6	-	-	-	
			FTC (Gas)	1.4	-	-	1.4	2.1	3.2	3.8	4.2	-	1.4	1.4	1.4	
			FTC (Liq.)	1.4	-	-	1.4	2.1	2.1	2.1	2.1	2.1	-	1.4	1.4	1.4
		70	FTO/FTC	-	-	4.2	6.3	7.7	-	-	-	-	-	-	-	-
				-	-	-	-	-	7.7	9.1	11.2	-	-	-	-	-
				-	-	-	-	-	-	-	-	11.2	12.6	14.0	16.8	
	1050	60	FTO	-	1.4	0.7	2.1	3.5	4.9	6.3	4.9	5.6	-	-	-	
			FTC (Gas)	2.4	-	0.7	2.1	3.5	4.9	6.3	4.2	-	1.4	1.4	1.4	
			FTC (Liq.)	2.4	-	0.7	2.1	3.5	3.2	3.2	2.1	-	1.4	1.4	1.4	
		70	FTO/FTC	-	-	7.0	9.1	12.0	-	-	-	-	-	-	-	-
				-	-	-	-	-	12.0	14.0	16.9	-	-	-	-	-
				-	-	-	-	-	-	-	-	16.9	19.6	22.5	24.6	
700	60	FTO	-	2.4	1.4	3.5	5.6	7.7	9.8	12.6	14.8	16.3	18.9	21.0		
		FTC (Gas)	4.2	-	1.4	3.5	5.6	7.7	9.8	-	-	-	-	-		
		FTC (Liq.)	4.2	-	1.4	3.5	4.9	4.9	4.9	-	-	-	-	-		
	70	FTO/FTC	-	-	11.2	15.5	19.7	-	-	-	-	-	-	-	-	
			-	-	-	-	-	19.7	23.9	28.1	-	-	-	-	-	
			-	-	-	-	-	-	-	-	28.1	32.3	36.6	42.2		

Soft seal, Rolling diaphragm actuator (Spring range 0.5 ~ 1.0kgf/cm<sup>2</sup>)

Size Inch	Rated Cv	FTO ATO	FTO-ATC FTC-ATO Air supply - kgf/cm <sup>2</sup>					
			1.4	1.8	2.1	2.5	2.8	3.2
1	14	56.2	56.2	-	-	-	-	-
	8.4	70.3	70.3	-	-	-	-	-
	5.6	70.3	70.3	-	-	-	-	-
1 - ½	30	35.1	16.1	49.2	-	-	-	-
	18	70.3	22.5	70.3	-	-	-	-
	12	70.3	36.6	70.3	-	-	-	-
2	50	17.5	6.7	26.0	49.2	-	-	-
	30	36.6	9.8	37.3	70.3	-	-	-
	20	37.2	16.2	52.7	70.3	-	-	-
3	135	14.0	6.3	21.0	35.1	-	-	-
	81	29.5	9.1	29.5	52.0	-	-	-
	54	33.7	16.2	47.8	56.2	-	-	-
4	230	7.0	2.4	10.5	18.3	26.0	33.7	35.1
	138	14.8	3.5	14.8	26.7	38.0	49.9	56.2
	92	16.2	7.0	23.2	40.1	56.2	56.2	56.2

Soft seal, Rolling diaphragm / Cylinder actuator (Spring range 0.5 ~ 1.0kgf/cm<sup>2</sup>)

Size	Rated Cv	Type Actuator	Flow Direction	FTO ATO	FTO-ATC FTC-ATO Air supply - kgf/cm <sup>2</sup>									
					2.1	2.5	2.8	3.2	3.5	3.9	4.2	4.6	4.9	5.3
6	500	60	FTO	4.2	1.4	6.3	12.0	16.9	21.3	26.7	31.6	35.1	-	-
			FTC (Gas)	-	1.4	6.3	12.0	16.9	21.3	26.7	31.6	35.1	-	-
	FTC (Liq.)		-	1.4	6.3	12.0	16.9	21.3	21.0	21.0	21.0	-	-	
	70	FTO/FTC	-	24.6	42.2	-	-	-	-	-	-	-	-	-
	300	60	FTO	9.1	2.1	9.1	16.9	24.6	31.6	37.3	43.6	51.3	-	-
			FTC (Gas)	-	2.1	9.1	16.9	24.6	31.6	37.3	43.6	51.3	-	-
FTC (Liq.)	-		2.1	9.1	16.9	24.6	25.3	25.3	25.3	25.3	-	-		
70	FTO/FTC	-	35.1	56.2	-	-	-	-	-	-	-	-	-	
200	60	FTO	10.5	4.2	15.5	26.7	37.2	47.8	56.2	-	-	-	-	
		FTC (Gas)	-	4.2	15.5	26.7	37.2	47.8	56.2	-	-	-	-	
FTC (Liq.)		-	4.2	15.5	26.7	37.2	35.1	35.1	-	-	-	-		
70	FTO/FTC	-	52.7	56.2	-	-	-	-	-	-	-	-	-	
8	850	60	FTO	1.4	-	2.8	5.3	7.7	10.5	12.7	15.5	17.6	21.0	-
			FTC (Gas)	-	-	2.8	5.3	7.7	10.5	12.7	-	-	-	-
	FTC (Liq.)		-	-	2.8	5.3	6.3	6.3	6.3	-	-	-	-	
	70	FTO/FTC	-	11.2	16.9	21.0	-	-	-	-	-	-	-	-
	510	60	FTO	2.8	0.7	4.6	8.4	12.0	16.1	19.7	24.0	28.1	31.6	-
			FTC (Gas)	-	0.7	4.6	8.4	12.0	16.1	19.7	-	-	-	-
FTC (Liq.)	-		0.7	4.6	8.4	9.8	9.8	9.8	-	-	-	-		
70	FTO/FTC	-	17.6	26.7	31.6	-	-	-	-	-	-	-	-	
340	60	FTO	4.9	1.4	7.7	14.0	19.6	26.0	31.6	38.0	43.6	49.2	-	
		FTC (Gas)	-	1.4	7.7	14.0	19.6	26.0	31.6	-	-	-	-	
FTC (Liq.)		-	1.4	7.7	14.0	15.4	15.5	15.5	-	-	-	-		
70	FTO/FTC	-	28.1	42.2	49.2	-	-	-	-	-	-	-	-	
10	1300	60	FTO	-	-	1.0	2.4	3.9	5.3	6.7	7.7	9.1	10.5	12.0
			FTC (Gas)	-	-	1.0	2.4	3.9	5.3	6.7	7.7	-	-	-
	FTC (Liq.)		-	-	1.0	2.4	3.9	3.5	3.5	3.5	-	-	-	
	70	FTO/FTC	-	5.6	8.4	11.2	11.2	-	-	-	-	-	-	
	780	60	FTO	1.1	-	2.1	4.2	6.3	8.4	10.5	12.7	14.8	16.9	19.0
			FTC (Gas)	-	-	2.1	4.2	6.3	8.4	10.5	-	-	-	-
FTC (Liq.)	-		-	2.1	4.2	4.9	4.9	4.9	-	-	-	-		
70	FTO/FTC	-	9.1	13.4	17.5	-	-	-	-	-	-	-		
520	60	FTO	2.1	-	3.5	7.0	10.5	13.4	16.9	19.7	23.2	26.7	30.2	
		FTC (Gas)	-	-	3.5	7.0	10.5	13.4	16.9	-	-	-	-	
FTC (Liq.)		-	-	3.5	7.0	8.4	8.4	8.4	-	-	-	-		
70	FTO/FTC	-	14.8	21.8	28.1	-	-	-	-	-	-	-		
					-	-	28.1	31.6	31.6	-	-	-	-	

Size	Rated Cv	Type Actuator	Flow Direction	FTO ATO	FTO-ATC FTC-ATO Air supply - kgf/cm <sup>2</sup>										
					2.1	2.5	2.8	3.2	3.5	3.9	4.2	4.6	4.9	5.3	
12	1750	60	FTO	-	-	0.3	1.0	1.7	2.8	3.5	4.2	4.9	6.0	6.7	
			FTC (Gas)	-	-	0.3	1.0	1.7	2.8	3.5	4.2	-	-	-	
			FTC (Liq.)	-	-	0.3	1.0	1.7	2.1	2.1	2.1	-	-	-	
		70	FTO/FTC	-	3.2	4.9	6.3	-	-	-	-	-	-	-	-
				-	-	-	-	6.3	7.7	9.1	-	-	-	-	-
				-	-	-	-	-	-	-	9.1	11.2	14.0	-	-
	1050	60	FTO	-	-	0.7	2.1	3.2	4.5	5.6	7.0	7.7	9.1	10.5	
			FTC (Gas)	-	-	0.7	2.1	3.2	4.5	5.6	6.3	-	-	-	
			FTC (Liq.)	-	-	0.7	2.1	3.2	3.2	3.2	3.2	-	-	-	
		70	FTO/FTC	-	4.9	7.7	14.8	-	-	-	-	-	-	-	-
				-	-	-	-	9.8	12.0	14.0	-	-	-	-	-
				-	-	-	-	-	-	-	14.0	16.2	17.6	-	-
700	60	FTO	0.7	-	1.7	3.5	5.6	7.7	9.1	11.2	13.4	15.5	17.6		
		FTC (Gas)	-	-	1.7	3.5	5.6	7.7	9.1	9.8	-	-	-		
		FTC (Liq.)	-	-	1.7	3.5	4.9	4.9	4.9	4.9	-	-	-		
	70	FTO/FTC	-	8.4	12.7	16.2	-	-	-	-	-	-	-	-	
			-	-	-	-	16.2	19.7	21.0	-	-	-	-	-	
			-	-	-	-	-	-	-	21.0	21.0	21.0	-	-	

## Accessories

The rotary globe control valve provides a flow characteristic that is close to linear. For applications requiring high control accuracy and stable performance, a positioner and air filter regulator are recommended.

Optional accessories such as I/P converters, lock-up valves, limit switches, and solenoid valves can also be supplied to suit specific application requirements.

## Outline dimensions and weight

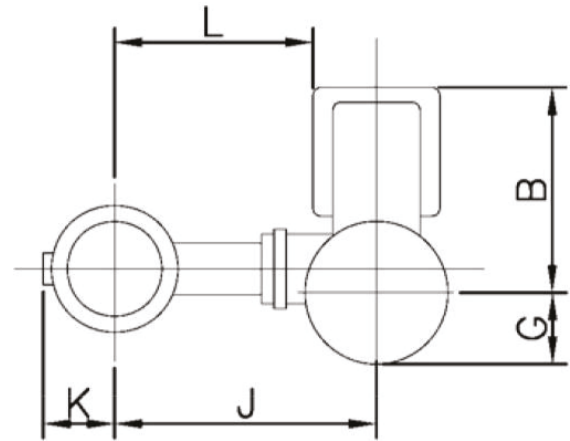
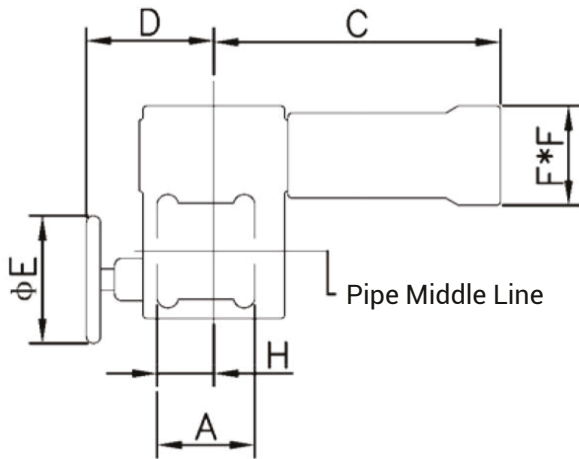

## Rolling Diaphragm Actuator

Unit: mm

Size	A	B	C	D	E	F	G	H	J	K	L	Weight (Kg)
	No Flange							No Flange				
1"	102	173	297	208	163	140	110	67	206	38	137	12
1½"	114	175	300	211	163	140	110	62	234	51	165	14
2"	124	175	300	211	163	140	110	62	239	66	170	16
3"	165	262	434	229	163	175	118	97	333	84	244	35
4"	194	264	437	229	163	175	118	106.5	356	109	267	48
6"	229	330	533	302	254	218	197	127	432	147	323	86
8"	243	333	536	302	254	218	197	147	470	203	361	127
10"	297	335	538	310	254	218	197	167	547	251	465	156
12"	338	338	541	312	254	218	197	184	610	277	500	184

## Piston Type Actuator

Unit: mm

Size	A	B	C	D	E	F	G	H	J	K	L	Weight (Kg)
	No Flange							No Flange				
6"	229	330	677	302	254	271	213	127	432	147	297	194
8"	243	333	680	305	254	271	216	147.5	470	203	335	236
10"	297	335	683	310	254	271	221	167	574	251	440	263
12"	338	338	686	312	254	271	224	184	610	277	475	290

## List of Stud and Nut for connection between valve and pipe

DIN	PN16				PN25				PN40				PN60			
	MxL	b	Stud Qty	Nut Qty	MxL	b	Stud Qty	Nut Qty	MxL	b	Stud Qty	Nut Qty	MxL	b	Stud Qty	Nut Qty
25	M12 x 170	30	4	8	M12 x 170	30	4	8	M12 x 175	35	4	8	M16 x 195	35	4	8
40	M16 x 190	35	4	8	M16 x 195	35	4	8	M16 x 200	35	4	8	M20 x 215	40	4	8
50	M16 x 210	35	4	8	M16 x 210	35	4	8	M16 x 215	35	4	8	M20 x 230	40	4	8
80	M16 x 250	35	4	8	M16 x 255	35	7	14	M16 x 260	40	7	14	M20 x 280	40	7	14
	M16 x 85*	25			M16 x 90*	30	2	2	M16 x 90*	30	2	2	M20 x 100*	35	2	2
100	M16 x 280	40	7	14	M20 x 295	40	7	14	M20 x 300	40	7	14	M22 x 315	40	7	14
	M16 x 95*	30	2	2	M20 x 105*	30	2	2	M20 x 105*	35	2	2	M22 x 115*	35	2	2
150	M20 x 330	40	7	14	M22 x 345	40	7	14	M22 x 350	40	7	14	M22 x 315	45	7	14
	M20 x 95*	35	2	2	M22 x 90*	35	2	2	M20 x 100*	35	2	2	M22 x 115*	35	2	2
200	M20 x 350	40	7	14	M22 x 370	40	10	20	M22 x 350	45	7	14	M30 x 380	50	7	14
	M20 x 90*	35	2	2	M22 x 100*	40	4	4	M22 x 100*	40	2	2	M30 x 115*	45	2	2
250	M22 x 450	40	8	16	M27 x 475	45	12	24	M30 x 455	45	8	16	M36 x 480	50	8	16
	M22 x 105*	40	8	8	M27 x 110*	40	8	8	M30 x 120*	45	8	8	M36 x 135*	50	8	8
300	M22 x 460	45	8	16	M27 x 475	45	12	24	M30 x 500	45	12	24	M36 x 530	50	12	24
	M22 x 105*	40	8	8	M37 x 110*	40	8	8	M30 x 130*	45	8	8	M36 x 145*	50	8	8

Note: " \* " means double ends stud

## List of Stud and Nut for connection between valve and pipe

ANSI Spec Size	150#				300#				600#			
	M x L	b	Stud Qty	Nut Qty	MxL	b	Stud Qty	Nut Qty	MxL	b	Stud Qty	Nut Qty
25	M14 x 185	30	4	8	M16 x 195	35	4	8	M18 x 210	40	4	8
40	M14 x 200	30	4	8	M20 x 255	40	4	8	M20 x 235	40	4	8
50	M16 x 225	35	4	8	M16 x 230 M16 x 95*	40	7 2	14 2	M18 x 250 M18 x 105*	40	7 2	14 2
80	M18 x 270	35	4	8	M20 x 305 M20 x 130*	40	7 2	14 2	M20 x 310 M20 x 140*	40	7 2	14 2
100	M18 x 295 M18 x 105*	35	4	8	M16 x 230 M16 x 95*	40	7 2	14 2	M22 x 355 M22 x 150*	ANSI ANSI	ANSI ANSI	ANSI ANSI
150	M20 x 355 M20 x 120*	40	7 2	14 2	M20 x 365 M20 x 150*	45	7 2	14 2	M22 x 355 M22 x 150*	40	7 2	14 2
200	M20 x 365 M20 x 105*	40	6 4	12 4	M27 x 405 M24 x 125*	50 45	10 4	20 4	M30 x 460 M27 x 150*	55 45	10 4	20 4
250	M22 x 425 M22 x 110*	40	8 8	16 8	M27 x 475 M27 x 130*	50 45	12 8	24 8	M33 x 535 M33 x 165*	65 45	12 8	24 8
300	M22 x 470 M22 x 110*	45	8 8	16 8	M30 x 525 M30 x 140*	65 45	12 8	24 8	M33 x 580 M33 x 165*	65 50	16 8	32 8

Note: " \* " means double ends stud

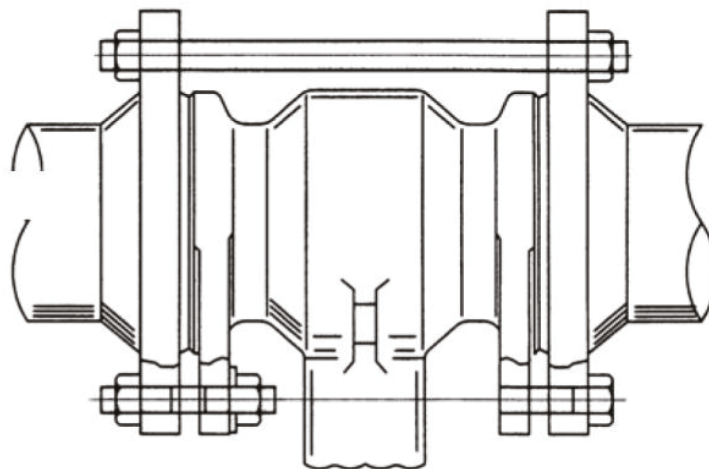

## REQUEST FOR QUOTE

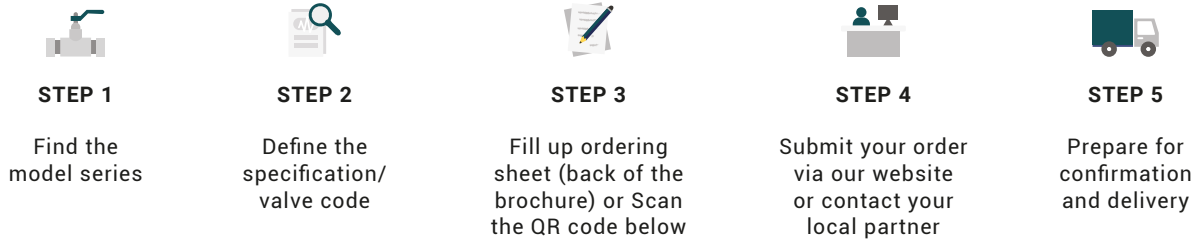

\*For further assistance with placing your order, please contact your local partner. A sales engineer will be assigned to assist you.

### Valve Coding Sheet Rotary Globe Control Valve

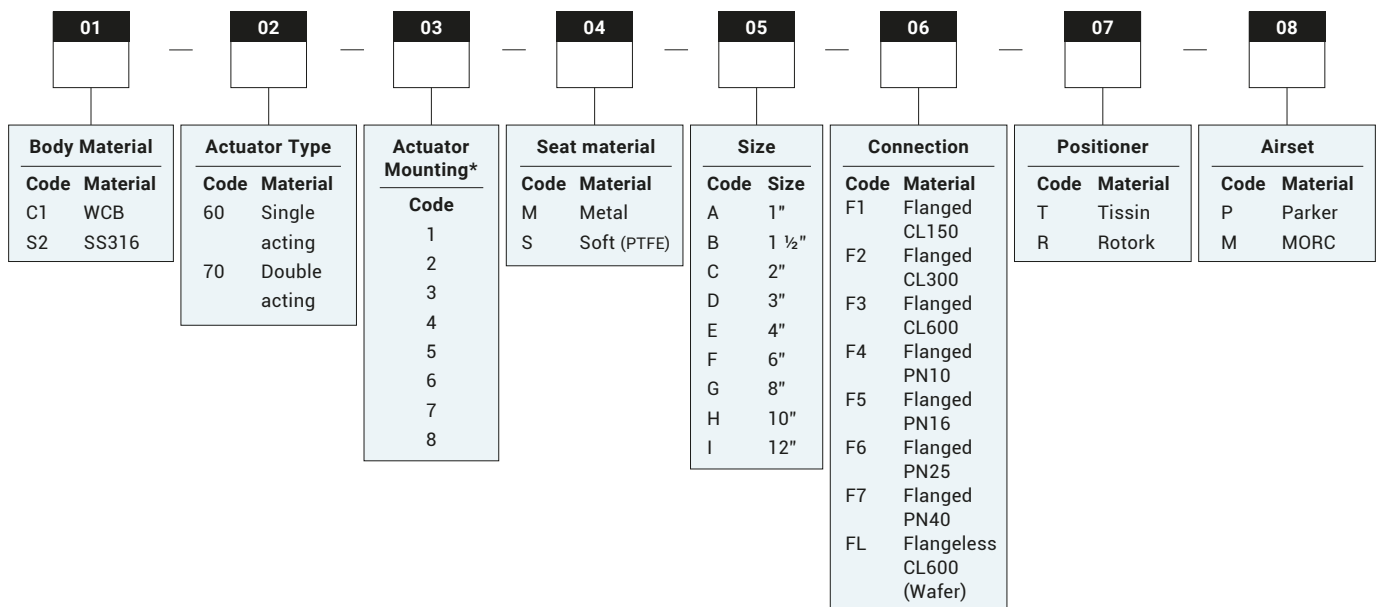

Your Valve Ordering Code:

RG —  01  02  03  04  05  06  07  08

Example:

RG-S2602MAF1TP.  
SS316 Material. Single Acting Actuator. Mounting type 2: Actuator parallel to pipe- Air to open. Metal seat. 1 inch size. Flanged to CL150. Tissin positioner. Parker airset.

\*For special material or customisation, please refer to our sales engineer.  
\*Specify the required valve and actuator orientation by selecting the corresponding position number in Actuator Mounting Guide Page.



SCAN FOR ONLINE ORDERING FORM

#### Distributor Details:

Tel : +65 6909 1221  
Email : enquiry@valvewerkz.com  
Website: www.valvewerkz.com



**Distributor Details:**  
**Valvewerkz Pte Ltd**  
14 Gul Ave Singapore 629657

Tel : +65 6909 1221  
Email : [enquiry@valvewerkz.com](mailto:enquiry@valvewerkz.com)  
Website: [www.valvewerkz.com](http://www.valvewerkz.com)